

Air Heater

Air Top 24/32

Gasoline/Diesel

HL 24/32 B

Gasoline

HL 24/32 D

Diesel

Workshop Manual

Preface

This Workshop Manual is intended to provide the information required to become familiar with all versions of the heaters of the series HL24/32 Petrol and Diesel as well as Air Top 24/32 Petrol and Diesel. The Air Top Heaters are an upgrade of the HL type heaters. The differences are described in this Workshop Manual. Although this Workshop Manual is no substitute for the Webasto Training Course, it will, however, prove useful for activities such as initial operation, maintenance, repair or even installation and removal of the heaters.

Due to the different fields of application as well as the continuous further development of the heaters, this Workshop Manual cannot cover all problems that may arise. If required, consult also other Webasto publications.

Operating Instructions	HL24/32 (Petrol and Diesel) Air Top 18/24/32 (Petrol and Diesel)
Installation Instructions	HL24/32 (Petrol and Diesel) Air Top 18/24/32 (Petrol and Diesel)
Spare Parts List	HL24/32 (Petrol and Diesel) Air Top 24/32 (Petrol and Diesel)
Catalogue	Heater Accessories Accessories for Air Ducting Systems
Technical Bulletins	
Webasto Information	

NOTE

As the heaters HL24/32 B as well as Air Top 24/32 B and HL24/32 D as well as Air Top 24/32 D are identical in appearance, they are identified by adhesive labels marked "Petrol" or "Diesel". Air Top 24/32 heaters can be identified by their housings painted in a matt gray colour. The heaters may only be operated with the prescribed fuel (in the case of Diesel versions, also heating oil EL may be used) and in compliance with the electrical requirements. Voltage-dependent electrical components are provided with red labels in the case of 12-volt heaters and green labels in the case of 24-volt heaters.

The TRS version can be recognized from the decal "product conforms to TRGVs/TRS" (= Technical Guidelines for hazardous materials/regulations for road transport)

Contents

1	Technical Data	4
1.1	Technical Data of the Heaters	4
1.2	Permissible Diameters and Lengths of Connecting Leads	5
1.3	Overview of heater variants	5
2	General Description	6
2.1	Air Heater HL 24/32 B/D	6
2.2	Air Heater Air Top 24/32	7
3	Putting into Service	8
3.1	General Notes	8
3.2	Bleeding the Fuel Supply System	8
3.3	Checking Proper Combustion	8
4	Troubleshooting (Quick Diagnosis)	9
5	Functional Description	12
5.1	Sequence of Functions (Heaters with Electronic Control Units SG 1561, SG 1561 GT and SG 1561 GS)	12
5.1.1	Switching the Heater On	12
5.1.2	Combustion	12
5.1.3	Start-Up Following Control Idle Period	12
5.1.4	Switching the Heater Off	13
5.1.5	Fault Lock-Out	14
6	Components	15
6.1	Components of the Heater	15
6.1.1	Electric Motor (Drive) with Combustion Air Fan	15
6.1.2	Combustion Air Fan	16
6.1.3	Combustion Air Adjusting Screw (Setscrew)	16
6.1.4	Fuel Feed With Burner Mat (Vaporizer)	17
6.1.5	Glow Plug (Not Applicable to Air Top!)	18
6.1.6	Pencil-Tape Glow Plug (Unique to Air Top)	18
6.1.7	Flame Detector	19
6.1.8	Temperature Limiter and Safety Switch	20
6.1.9	Heat Exchanger	21
6.1.10	Combustion Chamber (Burner Tube)	21
6.2	Fuel System	22
6.2.1	Metering Pump	22
6.2.2	Fuel System	23
6.2.3	Fuel Pickup	24
6.2.4	Fuel Filter	24
6.2.5	Tank Extracting Device	24

6.3 Exhaust and Combustion Air System	26
6.3.1 Pressure Equalizer (Exhaust/Intake Duct).....	26
6.3.2 Exhaust Silencer.....	26
6.3.3 Flexible Exhaust Pipe.....	26
6.3.4 Combustion Air Pipe.....	26
6.4 Electrical Parts	27
6.4.1 Electronic Control Unit	27
6.4.2 Resistor (Part Load)	28
6.4.3 Glow Plug Series Resistor 0.61 ohms (optional).....	28
6.4.4 Glow Plug Series Resistor 0.27 ohms (optional).....	28
6.4.5 Pulse-Controlled Glow Plug Relay (only in conjunction with SG 1561) (optional)	29
6.4.6 Wiring Harness HL 24/32	30
6.4.7 Wiring Harness Air Top 24/32.....	31
6.4.8 Conversion Kit	32
7 Notes on Repair and Disassembly	33
7.1 General Important Repair Instructions.....	33
7.1.1 Installation and Removal of Heater.....	33
7.1.2 Work on the Vehicle.....	33
7.1.3 Test Run of the Heater	33
7.2 Disassembly Instructions	34
7.3 Tools and Measuring Instruments.....	36
7.3.1 Testing Device	36
7.3.2 Glow Plug Wrench.....	36
7.3.3 Measuring Tools and Instruments.....	36
8 Maintenance of the Heater	37
9 Wiring diagrams	38

1 Technical Data

1 Technical Data

1.1 Technical Data of the Heaters

Unless tolerances are shown within the technical data table, a tolerance of $\pm 10\%$ applies at an ambient temperature of $+20^{\circ}\text{C}$ and at the rated voltage.

Heater			HL 24 B / Air Top 24	HL24 D / Air Top 24 HL 24 D (TRS)	HL 32 B / Air Top 32	HL 32 D / Air Top 32 HL 32 D (TRS)
Mark of conformity			- S 218	- S 219	- S 207	- S 206
Type			Air Heater with vaporizing-type burner			
Heat output	full load	kW	2,4 (2050 kcal/h)		3,2 (2750 kcal/h)	
	part load	kW	1,2 (1050 kcal/h)		1,6 (1400 kcal/h)	
Fuel			Petrol DIN 51 600 DIN 51 607	Diesel fuel DIN 51601 or grades and admixtures in compliance with respec- tive engine manufac- turer's specifications. heating oil DIN 51603	Petrol DIN 51 600 DIN 51 607	Diesel fuel DIN 51601 or grades and admixtures in compliance with respec- tive engine manufac- turer's specifications. heating oil DIN 51603
Fuel consumption	full load	kg/h	0,24 (0,32 ltr/h)	0,24 (0,28 ltr/h)	0,32 (0,42 ltr/h)	0,31 (0,37 ltr/h)
	part load	kg/h	0,12 (0,16 ltr/h)	0,12 (0,14 ltr/h)	0,16 (0,21 ltr/h)	0,16 (0,19 ltr/h)
Rated voltage		V DC	12 or 24			
Operating voltage range		V DC	10 ... 14 or 20 ... 28			
Rated power consumption (not during start-up operation)	full load	W	18	18 (TRS = 25)	32	32 (TRS = 39)
	part load	W	12	12 (TRS = 19)	22	22 (TRS = 29)
Max. ambient temperature during operation:						
- heater		$^{\circ}\text{C}$	- 40 ... + 40			
- electronic control unit		$^{\circ}\text{C}$	- 40 ... + 75			
- metering pump		$^{\circ}\text{C}$	- 40 ... + 20			
- TRS solenoid valve		$^{\circ}\text{C}$	- 40 ... + 80			
Max. storage temperature:						
- heater		$^{\circ}\text{C}$	- 40 ... + 85			
- electronic control unit		$^{\circ}\text{C}$	- 40 ... + 85			
- metering pump		$^{\circ}\text{C}$	- 40 ... + 85			
Max. heating air inlet temperature		$^{\circ}\text{C}$	max. + 40			
Volumetric flow rate of heating air	full load	m^3/h	95 at approx. 0,50 mbar		130 at approx. 0,50 mbar	
	part load	m^3/h	68 at approx. 0,25 mbar		81 at approx. 0,25 mbar	
CO ₂ content in exhaust gas (at full load):						
- permissible operating range		% by vol.	9,5 ... 12,0			
- setting value at rated voltage		% by vol.	10,0 ... 10,5			
CO content in exhaust gas, max. perm. limits		% by vol.	0,2 (2000 ppm)			
HC content in exhaust gas (at nominal load and no-wind conditions)		% by vol.	0,01 (100 ppm)			
NO _x content in exhaust gas (at nominal load and no-wind conditions)		% by vol.	0,02 (200 ppm)			
Soot number acc. to Bosch, Bacherach		max.	< 4,0			
Motor nominal speed	full load	min^{-1}	2600 \pm 10 %		3300 \pm 10 %	
	part load	min^{-1}				
Dimensions of heater: (tolerance ± 3 mm)						
length		mm	420			
width		mm	186			
height		mm	184			
Dimensions of metering pump: (tolerance ± 3 mm)						
length		mm	152			
width		mm	74			
height		mm	70			
Dimensions of control unit 1561: (tolerance ± 3 mm)						
length		mm	97			
width		mm	102			
height		mm	36			
Weight:	heater	kg	5,90			
	control unit	kg	0,27			
	metering pump	kg	0,35			

Electrical Components:

Electronic control unit, motor, metering pump, glow plug in the case of HL 24/32, or pencil-type glow plug in the case of Air Top 24/32, part-load resistor, digital timer (except for TRS versions) and lamp for switch are designed for either 12-volt or 24-volt operation.

Components such as temperature limiter, flame detector and switch for heater support are the same on 12-volt and 24-volt units.

The TRS solenoid valve for combustion air is designed for 24-volt operation only.

1.2 Permissible Diameters and Lengths of Connecting Leads

Fuel line, suction side: 1) - inside diameter - maximum length - maximum suction height	2 - 3 mm 3,0 m see pos. 6.2
Fuel line, pressure side: 1) - inside diameter - maximum length - maximum pumping head	2 mm 10 m see pos. 6.2
Combustion air intake line: - min. inside diameter - maximum length - maximum bending range - smallest bending radius	30 mm 5 m 360° < 45 mm
Exhaust pipe: - min. inside diameter - maximum length - maximum bending range - smallest bending radius	30 mm 5 m 360° < 85 mm
Heating air line: - min. inside diameter	80 mm

1.3 Overview of heater variants

Heater type	Voltage	Operation	Comment
HL 24D.01	12 V	Diesel	with 12V glow plug
HL 24D.02	24 V	Diesel	with 12V glow plug
HL 24B.61	12 V	Petrol	with 12V glow plug
HL 24B.62	24 V	Petrol	with 12V glow plug
Air Top 24	24 V	Diesel	with pencil-type glow plug
HL 32D.01	12 V	Diesel	with 12V glow plug
HL 32D.02	24 V	Diesel	with 12V glow plug
HL 32D.04	24 V	Diesel	with 24V glow plug
HL 32D.06	24 V	Diesel	with 24V glow plug (MAN)
HL 32B.61	12 V	Petrol	with 12V glow plug
HL 32B.62	24 V	Petrol	with 12V glow plug
HL 32B.64	24 V	Petrol	with 24V glow plug
Air Top 32	24 V	Diesel	with pencil-type glow plug

CAUTION:

Only materials capable of withstanding a temperature of at least 130°C may be used as heating tubes.

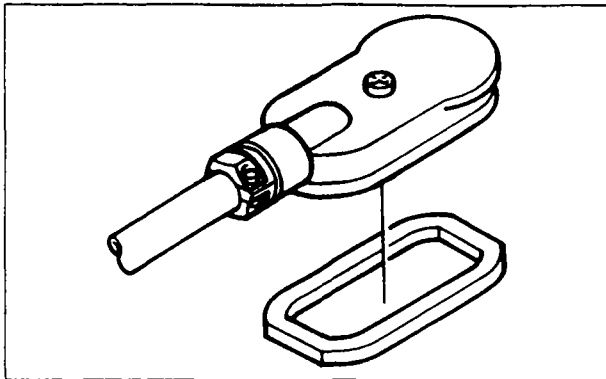

CAUTION:

Be sure to replace the seal located underneath the cap (wiring harness) upon every re-installation of the wiring harness.

2 General Description

2 General Description

2.1 Air Heater HL 24/32 B/D

The heater basically consists of an electric motor (2) serving as driving unit for the hot air and combustion air fans, a housing accommodating the combustion chamber, the glow plug and the flame detector, as well as the heat exchanger.

At the top of the housing the glow plug and the flame detector are installed - easily accessible for service purposes. The combustion air adjusting screw can also be accessed from above. The temperature limiter is mounted to the heat exchanger.

The entire unit is enclosed by two housing halves - split lengthwise - and two end covers ("blue" for inlet, "red" for outlet).

A metering pump, an electronic control unit SG 1561 or SG 1561 GT and a heater control are required to operate the heater.

The combustion air fan supplies the required air quantity - adjustable by means of the combustion air adjusting screw - which is introduced into the combustion chamber through ports. The fuel/air "mixture" which is formed by the fuel vaporizing at the burner matting is ignited by the activated, pulse-controlled glow plug (applies only to electronic control unit SG 1561 GT). The heater unit is started up at full load. Combustion takes place in the combustion chamber fitted inside the heat exchanger.

The heating air fan takes in "cold" air which then flows around the heat exchanger where the air is heated, and the hot air is then discharged at the outlet.

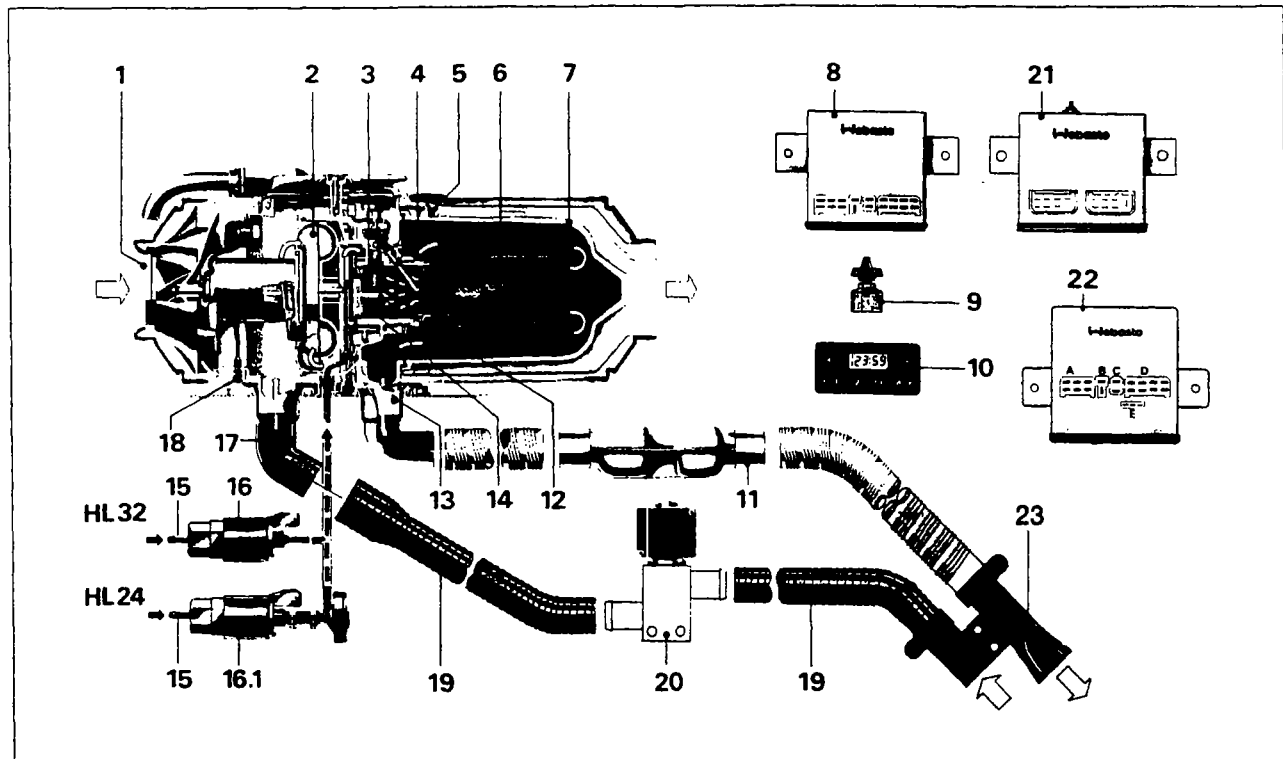

Air Heater HL 24 B/D or HL 32 B/D

- | | | | |
|----|---|------|---------------------------------|
| 1 | Heating air fan | 15 | Fuel connection |
| 2 | Combustion air fan with motor | 16 | Metering pump for HL32 |
| 3 | Glow plug | 16.1 | Metering pump for HL24 |
| 4 | Flame detector | 17 | Combustion air inlet |
| 5 | Temperature limiter | 18 | Safety switch |
| 6 | Combustion chamber | 19 | Tube** |
| 7 | Heat exchanger | 20 | Solenoid valve** |
| 8 | Electronic control unit 1561 | 21 | Electronic control unit 1547** |
| 9 | Switch | 22 | Electronic control unit 1561 GT |
| 10 | Digital Timer (except for TRS) | 23 | Pressure equalizer |
| 11 | Exhaust gas silencer | | |
| 12 | Heat deflector plate
(only for Diesel-type heater) | | |
| 13 | Exhaust gas outlet | | |
| 14 | Vaporizer (matting) * | | |

* different for Benzin and Diesel types
** (only for TRS)

2.2 Air Heater Air Top 24/32

The heating unit consists of the following assemblies: heat exchanger, burner and drive unit.

The pencil-type glow plug (6) and the flame detector (7) are fitted inside the housing - easily accessible for servicing purposes. The combustion air fan supplies the required air quantity, adjustable by means of the combustion air adjusting screw (see sect. 7.1.3), which flows into the combustion chamber through ports.

The mixture which is formed by the fuel vaporizing at the vaporizer (5) is ignited by the activated, pulse-controlled pencil-type glow plug (6). The heater is started up at part load. Combustion takes place in the combustion chamber (9) fitted inside the heat exchanger (10).

The temperature limiter (8) is mounted to the heat exchanger (10). A metering pump (20/21) and an electronic control unit (15) are required for the operation of the heater.

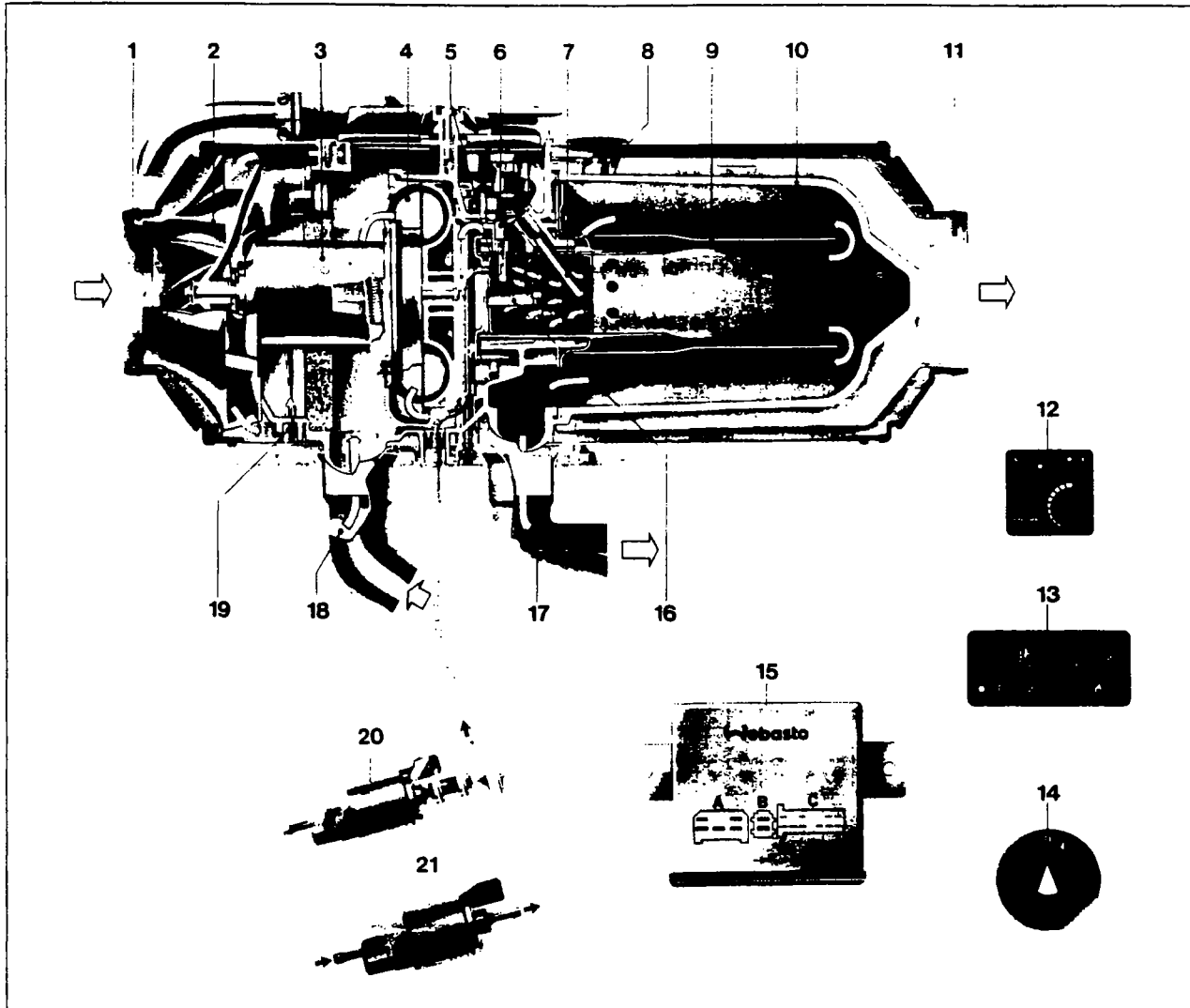

Air Heater Air Top 24 B/D or Air Top 32 B/D

- | | |
|-------------------------------|---|
| 1 Heating air inlet | 13 Digital Timer (except for TRS) |
| 2 Heating air fan | 14 Switch |
| 3 Motor | 15 Electronic control unit 1561 GS, order no. 241 89A |
| 4 Combustion air fan | 16 Heat deflector plate (only for Diesel variant) |
| 5 Vaporizer * | 17 Exhaust gas outlet |
| 6 Pencil-type glow plug | 18 Combustion air inlet |
| 7 Flame detector | 19 Safety switch |
| 8 Temperature limiter | 20 Metering pump for Air Top 24 |
| 9 Combustion chamber | 21 Metering pump for Air Top 32 |
| 10 Heat exchanger | |
| 11 Heating air outlet | |
| 12 Mechanical room thermostat | |
- * different for Benzin and Diesel variants

3 Putting into Service

3 Putting into Service

3.1 General Notes

Following the installation of the heater, the vehicle's fuel supply system is to be thoroughly bled. The vehicle manufacturer's directions are to be observed when so doing.

During a trial run of the heater, all connections are to be checked for leaks and security. Should the heater fail during operation, troubleshooting is to be performed in accordance with chapter 4.

All electrical components can be checked after the cap (of wiring harness) has been removed.

3.2 Bleeding the Fuel Supply System

When the heater is switched on, the metering pump must first fill the entire fuel supply system. If combustion is not established during the first start-up phase (incl. repeated start-up), the heater may have to be switched off and then on again (several times, if necessary).

NOTE:

Owing to the low fuel consumption repeated switching on is required to fill the fuel line.

Rapid filling of the fuel line can also be accomplished as follows:

- connect the positive conductor of the metering pump to the +30 terminal via pushbutton switch (e.g. order no. 375.004) (see Fig.)
 - repeated switching on and off causes the fuel metering pump to operate until the line is filled
- In the event of an empty line owing to a completely empty fuel tank the heater should be started repeatedly only with the vehicle engine running in order to keep battery drain to a minimum.

3.3 Checking Proper Combustion

After the heater has been subjected to a trial run - also after a replacement of the combustion air fan - the CO₂ content in the exhaust gas is to be measured (correct voltage to be observed).

Should the measured CO₂ value exceed the tolerance range (see sect. 6.1.3) the combustion air fan must be checked (see sect. 6.1.2) or the fuel supply rate measured (see sect. 6.2.1). When replacing the combustion air fan (drive unit) and/or the metering pump, the CO₂ value must be checked and readjusted, if necessary (see sect. 6.1.3).

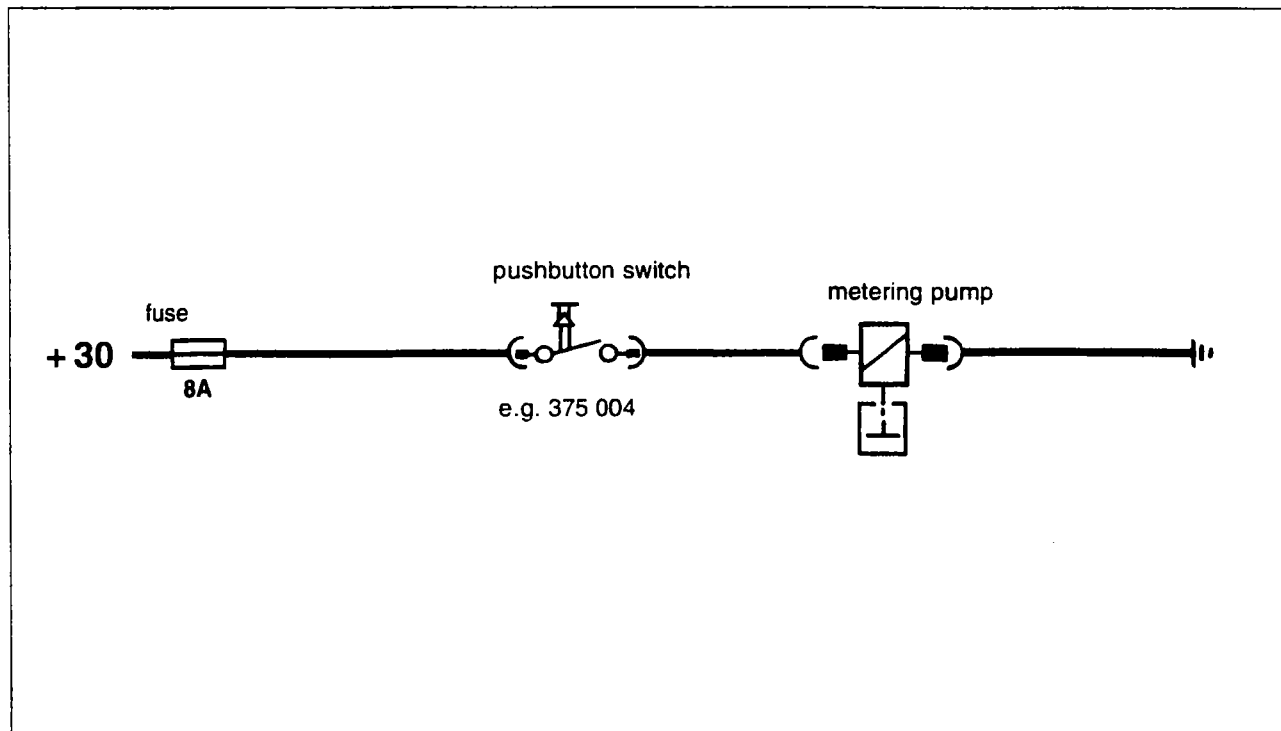

4 Troubleshooting (Quick Diagnosis)

NOTE:

In the event of a malfunction, fuses and electrical connections should always be checked for security and proper condition prior to proceeding with any troubleshooting activity.

Fault condition	Check and repair or replace, if required																			
	Power supply	Fuses	El. leads and connections (+/-)	Switches	Temperature limiter	Flame detector	Thermostat (room thermostat)	Electronic control unit	Glow plug (voltage ≤ 9,5 volts)	Operation indicator light	Drive (motor)	Fuel supply	Metering pump	Heating air tubes	Combustion air ducting	Exhaust gas pipes	Switch (safety switch)	Part-load resistor	Pulse-controlled glow plug relay	
After switching on - no function	•	•	•	•				•	•											
Only after repeatedly switching on - combustion									•			•	•							•
No glow plug voltage	•	•	•	•			•	•	•											•
Insufficient glow plug voltage	•	•	•					•												
Drive (motor) starts immediately *				•				•												
Drive (motor) fails to start	•	•	•	•				•			•									
Combustion - not established			•		•			•	•			•	•		•	•	•			•
Combustion - cuts out			•		•							•	•	•				•		
Combustion - white smoke												•								
Combustion - black smoke											•				•	•				
Heater overheats							•							•						
Drive (with motor in after-running phase) fails to shut down								•												
Cycling of metering pump - not audible	•	•	•	•	•			•	•				•						•	
Cycling of metering pump - irregular								•					•							
Fault lock-out - after approx. 240 seconds							•					•							•	
Fault lock-out - after approx. 30 seconds							•													
Motor stops in part-load mode			•					•												•

* Possible interruption glow plug/pencil-type glow plug (applies only to SG 1561 GT and 1561 (order no. 241 89A))
Defective flame detector (applies only to SG 1561 GS)

4 Troubleshooting (Quick Diagnosis)

Troubleshooting is facilitated by using the testing device (see sect. 7.2).

Heater shuts down in its 'fault lock out' mode (applies only to HL 24/32 if equipped with el. control unit SG 1561)

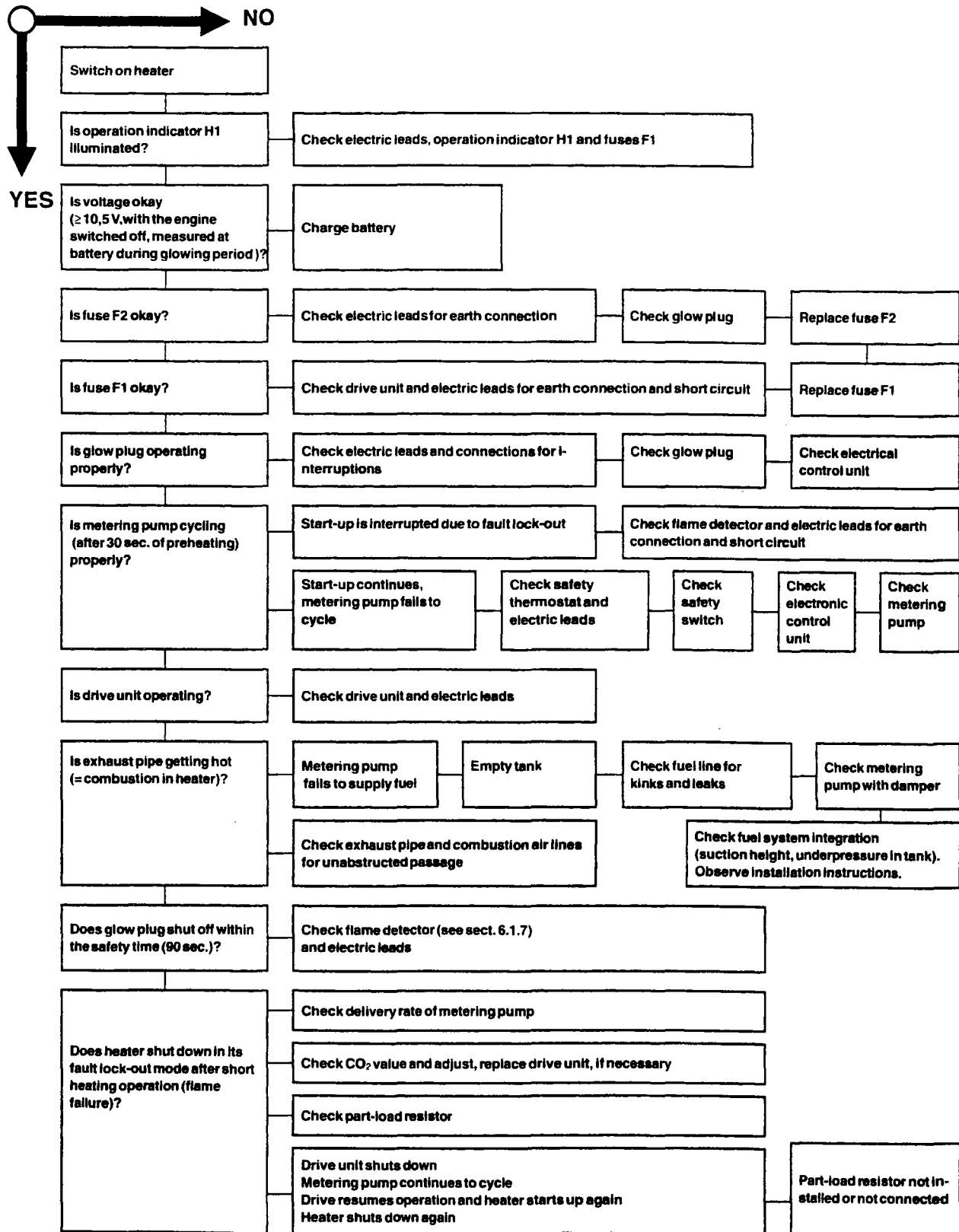

Heater gives off too little heat (applies to electronic control units 1561, 1561 GT and 1561 GS)

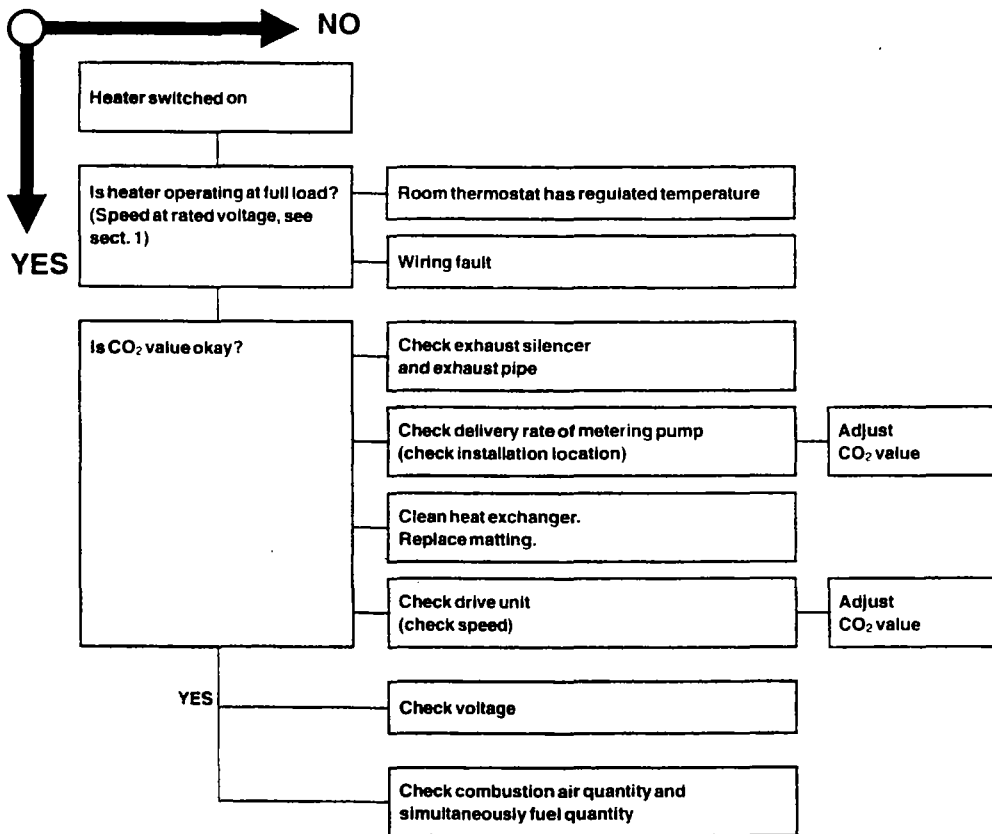

Heater shuts down due to faults during heating operation
(applies to electronic control units 1561, 1561 GT and 1561 GS)

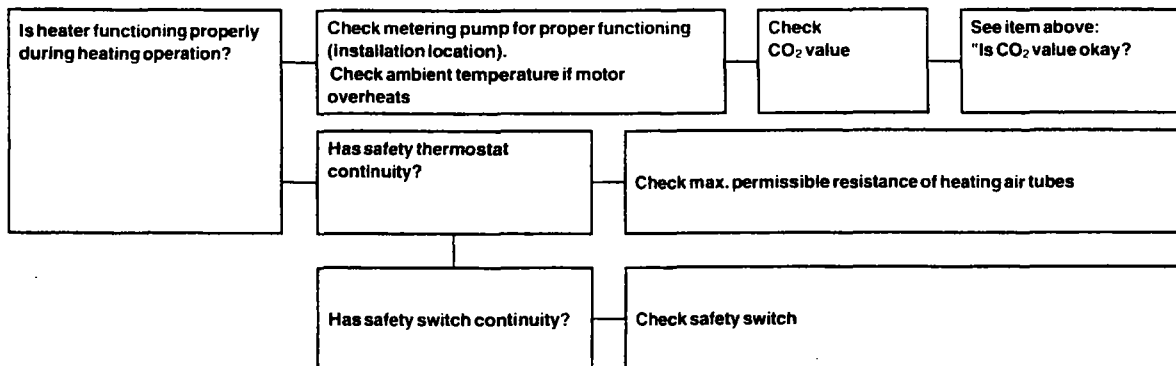

5 Functional Description

5 Functional Description

5.1 Sequence of Functions

(Heaters with Electronic Control Units SG 1561, SG 1561 GT and SG 1561 GS)
(see also Functional Diagram)

The description below refers to wiring diagram B 8014-3000-0008/-0009, see "Wiring Diagram", see pp. 39

5.1.1 Switching the Heater On

Positive voltage is continuously supplied to electronic control unit connector A2 via fuse F1, and to control unit connector A1 via fuse F2. Upon switching on, positive control voltage is also supplied to the electronic system of the control unit via control unit connector A6.

- Operation indicator light is illuminated.
- Closing relay is energized
- Glow-plug operation is activated via relay K1
- TRS: The solenoid valve in the combustion air line opens.
- After preheating (approx. 25 sec. for SG 1561 GS, approx. 30 sec. for SG 1561 GT), positive pulsed voltage is applied to control unit connector D3 (applies to control unit 1561 and 1561 GT), or C10 (control unit 1561 GS) via transistor V101/T (no pulse-control relay exists in control unit SG 1561). Control unit connector D3/C10 supplies metering pump Y via temperature limiter B2 and safety switch S3/S6.
- Safety time (max. 90 sec.) and fuel inlet flow time (approx. 5 sec.) commence.
- After the fuel inlet flow time has elapsed, motor M is switched on via relay K2 and electronic control unit connector D1/C4.

NOTE:

In the case of Air Top 24/32 equipped with SG 1561 GS the motor starts at partial load after overcoming a breaking-off torque and after 20 seconds switches over to full load.

If flames have formed during the safety time, flame detector B1 signals "light" and relay K1 is released. Safety time is reset and the glow plug/pencil-type glow plug (SG 1561 GS) is switched off. In the case of proper ignition this procedure lasts approx. 15 seconds.

Restarting: If no flame has materialized during the safety time, a second start-up attempt is carried out automatically.

5.1.2 Combustion

The heater, which is now operating, continues to run until the control voltage is interrupted at control unit connector A6. This occurs either when the heater is switched off manually or when the preset operating time has elapsed, or by the room thermostat.

Depending on the amount of heat required, the heater can remain in the "combustion mode" or "part load mode" (i.e. heating operation at reduced heat output) for an extended period of time.

5.1.2.1 Start of Part Load Operation

If the system is equipped with a room thermostat B3, the latter closes as soon as the preset room temperature has been reached. Positive control voltage reaches plug A3. During part load operation, metering pump Y cycles at a lower frequency. After 20 sec. (HL 24/32) or 85 sec. (Air Top 24/32), motor M also operates at the lower part-load speed. The heater now operates at reduced output until the room temperature is at a level where the lower switching point of room thermostat B3 is reached.

During the entire part load phase the operation indicator remains on.

5.1.2.2 Start of Full Load Operation

When the room temperature has reached the lower switching point of room thermostat B3, the latter opens. The positive control voltage is removed from plug A3 and metering pump Y resumes operation at the higher full load frequency. After 10 sec. also motor M switches to the higher full load speed.

NOTE:

If a room thermostat with On/Off switch is used, this control operation can also be effected between part load mode and the Off state (control idle), depending on the switch position.

5.1.3 Start-Up Following Control Idle Period

After the room temperature has fallen to a certain level, the HL 24/32 heaters (fitted with glow plug) always start up at full load.

The Air Top 24/32 heaters (fitted with pencil-type glow plug) start up at part load after overcoming a break-away torque and change over to full load after 20 seconds.

Depending on the switch position, change-over to part load operation is effected after a minimum of 60 seconds operating at full load.

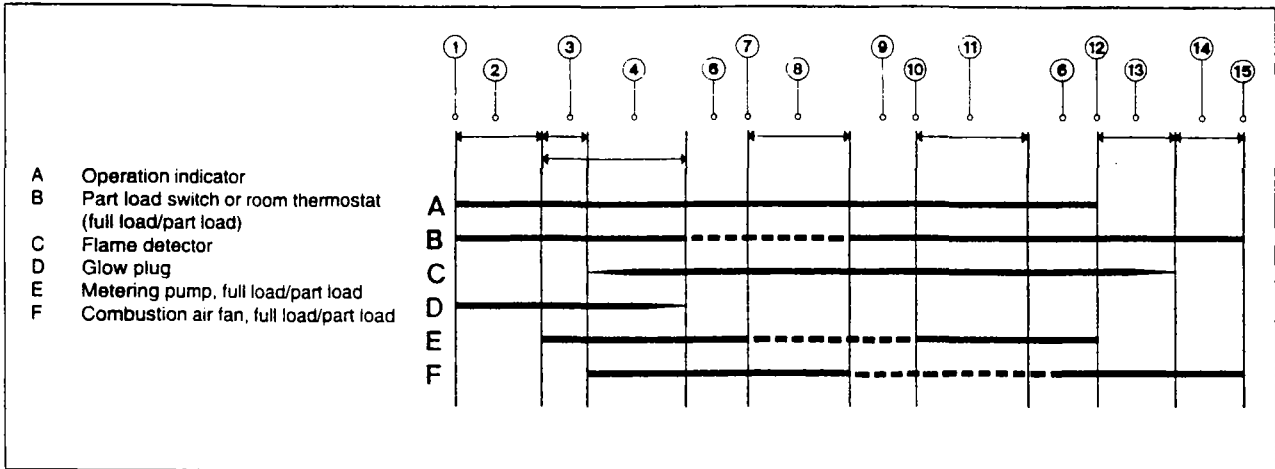

Functional Diagram of Pos. A2, Regular Sequence of Functions (Control Units 1561 and 1561 GT)

- | | |
|---|---|
| 1 Switching on | 10 Room temperature (setpoint value not reached) |
| 2 Preheating 30 sec. | 11 Change-over from part load to full load (10 sec.) |
| 3 Fuel inlet flow 5 sec. | 12 Switching off |
| 4 Safety time max. 90 sec. | 13 Optical after-run max. 80 sec. |
| 6 Combustion mode - full load | 14 Electronic after-run (HL24 = 150 sec./HL32 = 180 sec.) |
| 7 Room temperature (setpoint value reached) | 15 Off |
| 8 Change-over from full load to part load 20 sec. | * If no combustion is established, start-up is repeated automatically (30 sec. preheating, 90 sec. safety time) |
| 9 Combustion mode - part load | |

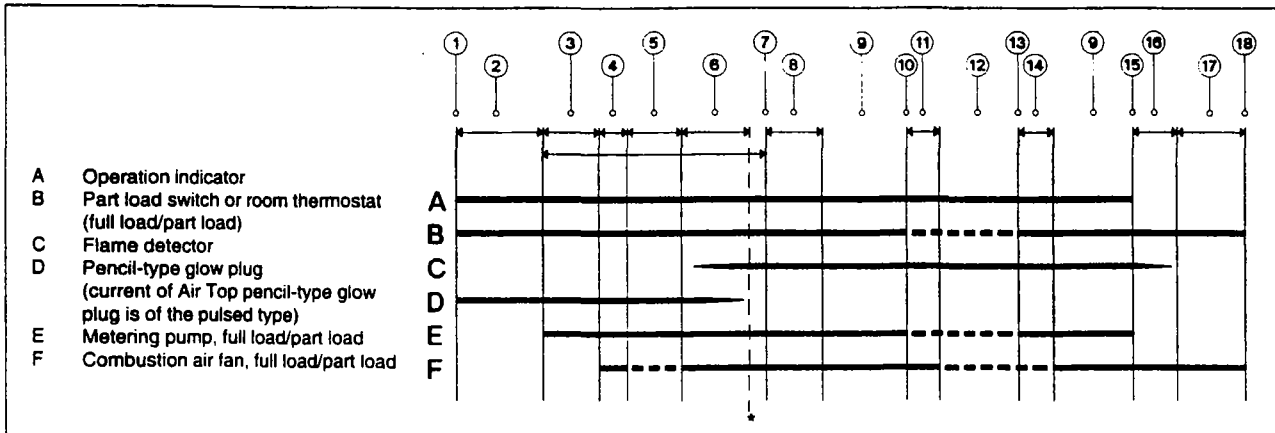

Functional Diagram of Pos. A2, Regular Sequence of Functions, Control Unit 1561 GS (order no. 241 89A)

- | | |
|---|---|
| 1 Switching on | 12 Combustion mode - part load |
| 2 Preheating 25 sec., pulse-controlled | 13 Room temperature (setpoint value not reached) |
| 3 Fuel inlet flow 5 sec. | 14 Change-over from part load to full load (10 sec.) |
| 4 Full load start-up for motor to break away | 15 Switching off |
| 5 Part load start-up 20 sec. | 16 Optical after-run max. 80 sec. |
| 6 Full load start-up | 17 Electronic after-run (Air Top 24 = 150 sec./Air Top 32 = 180 sec.) |
| 7 Safety time max. 90 sec. | 18 Off |
| 8 Min. full load period 60 s | * If no combustion is established, start-up is repeated automatically (25 sec. preheating, 90 sec. safety time) |
| 9 Combustion mode - full load | |
| 10 Room temperature (setpoint value reached) | |
| 11 Change-over from full load to part load 8 sec. | |

5.1.4 Switching the Heater Off

When the heater is switched off manually or when the preset operating time has elapsed, the operation indicator extinguishes.

- Metering pump Y is switched off, fuel supply is interrupted.
- The after-run period starts immediately.

TRS: A short after-run period is initiated automatically

- if the heater is switched off (normally),
- if the vehicle's engine is switched off,
- if any fuel pumping device is put into operation.

5 Functional Description

5.1.4.1 After-Running Period

The after-running period is composed of the cooling period of the flame detector (approx. 20 sec.) and an electronic after-run period. If the flame detector fails to signal "dark" after 80 sec., the control unit initiates the after-run electronically thus ensuring that the heater will be switched off after 230 sec. or 260 sec., respectively, in any case.

After-running time:

HL24/Air Top 24	150 to 230 seconds
HL32/Air Top 32	180 to 260 seconds

NOTE:

The motor of the heating and combustion air fan always operates at full load during the after-running period.

The drive unit operates during the after-running period. After-running serves to ventilate the combustion chamber and thus to free it from gas and allows the heat exchanger to cool and so to prevent any damage due to overheating.

At the end of the after-running period, relay K2 is deenergized and motor M stops.

The heater is no longer in operation.

5.1.5 Fault Lock-Out

In the case of malfunctions the heater turns itself off automatically. The operation indicator continues to light until the unit is switched off at the main switch or via the timer. The "interlock" of the control unit can be cancelled by switching the control unit off and then on again (shut-off period min. 1 sec.).

5.1.5.1 Fault Lock-Out Because No Flame Has Materialized

- Switch-on as described under sect. 5.1.1
- If no proper combustion takes place within 120 sec. (30 sec. preheating + 90 sec. safety time), or 115 sec. (25 sec. preheating and 90 sec. safety time) if electronic control unit 1561 GS (order no. 241 89A) is used, the metering pump is switched off. Glow plug/pencil-type glow plug and combustion air fan remain in operation.
SG 1561 / SG 1561 GT = 30 sec.
SG 1561 GS = 10 sec.
Thereafter, the start-up sequence is repeated.
- The pulsed voltage at control unit connector D3/C 10 via transistor V101/T is removed.
- After a preheating time of approx. 30 sec. the positive pulsed voltage is applied again to control unit connector D3/C10 via transistor V101/T.

- Safety time (approx. 90 sec.) and fuel inlet flow time (approx. 5 sec.) start to elapse.
- After the fuel inlet flow time has elapsed, motor M is switched on again via relay K2 and control unit connector D1/C4, and the start-up sequence is repeated. Should combustion still fail to occur, the control unit will shut down the heater in its 'fault lock-out' mode within another 120 sec./115 sec., and an after-running period follows. The operation indicator continues to light.

5.1.5.2 Shut-Down Because Flame Extinguishes During Operation (e.g. Due to Lack of Fuel)

If the flame goes out during the combustion process and/or the flame detector B1 signals "dark", the glow plug/pencil-type glow plug is connected to the system for max. 90 sec. (safety time). If combustion is re-established, the heater resumes normal combustion operation.

If combustion is not established, metering pump and glow plug/pencil-type glow plug are switched off after a safety time of 90 sec. The control unit initiates the after-running period.

5.1.5.3 Shut-Down Due to Overheating

In the case of overheating, temperature limiter B2 interrupts the power supply to the metering pump. Fuel supply is thus stopped and the flame extinguishes. Prior to restarting, reset the temperature limiter pushing it in.

5.1.5.4 Shut-Down By Means of Safety Switch S6

Safety switch S6 interrupts the power supply to the metering pump if the heater does not rest properly on the holder (support).

5.1.5.5 Shut-Down During Preheating if Flame Detector is Defective

If during preheating (25 sec./30 sec.) the flame detector signals "light", the heater will shut down in its 'fault lock-out' mode.

6 Components

6.1 Components of the Heater

6.1.1 Electric Motor (Drive) with Combustion Air Fan

Description: The electric motor is a permanent-magnet motor and is designed to drive both the heating air and combustion air fans. The combustion air fan is rigidly connected to the motor.

A combustion air adjusting screw as well as a resistor (for part load operation) are fitted to the housing.

Check: Proper functioning of the combustion air fan or the E-motor, respectively, can be checked by means of a testing device.

Checking the motor speed at rated voltage with the motor installed:

	Air Top 24 B/D HL24 B/D	Air Top 32 B/D HL32 B/D
FL	2600 min ⁻¹ (±10%)	3300 min ⁻¹ (±10%)
PL	1850 min ⁻¹ (±10%)	2150 min ⁻¹ (±10%)

Check for chafing noises during the test. The combustion air fan together with the motor must be replaced if the following speeds are obtained:

	Air Top 24 B/D HL24 B/D	Air Top 32 B/D HL32 B/D
FL	< 2200 min ⁻¹	< 2800 min ⁻¹
PL	< 1550 min ⁻¹	< 1800 min ⁻¹

Reference dimension for gap between housing and impeller wheel = mm 0,3 ± 0,1mm.

CAUTION:

If this dimension is deviated from, the combustion air fan is to be replaced.

It is not possible to replace the motor or individual parts of the motor. The complete drive assembly must be replaced as a unit.

Removal:

- Remove cap (wiring harness) (Phillips screwdriver)
- Disconnect plug for motor, safety switch, temperature limiter and flame detector.
- Remove upper and lower housing halves (Phillips screwdriver)
- Remove covers (on inlet and outlet sides)
- Remove lockwasher and fan wheel from motor shaft
- Loosen motor cover (Phillips screwdriver)
- Loosen drive unit

Note section 6.1.3!

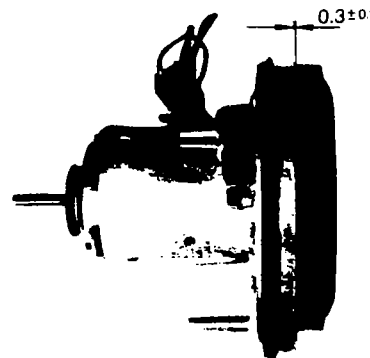
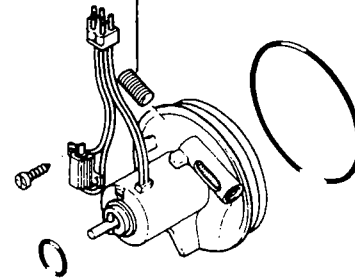

Installation: Installation is the reverse of removal. Complete electrical connections as shown in the connection diagram. The seal under the cap (wiring harness) must be replaced when so doing.

When installing the cap (wiring harness) torque it to 1 Nm.

Note: After the drive assembly has been replaced, the CO₂-value must be checked and readjusted, if necessary. (For adjusting procedure/specified value refer to section 6.1.3 "Combustion Air Adjusting Screw").

6 Components

6.1.2 Combustion Air Fan

Description: The combustion air fan is part of the drive assembly (see section 6.1.1). It is a ring-type blower of high accuracy and serves to supply the combustion air for the heater.

Check:

Check the motor speed (see section 6.1.1).

Check the CO₂-value (see section 6.1.3).

If the CO₂-value cannot be adjusted to the permissible value (10 -11% at nominal voltage), the fuel delivery rate is to be checked (see section 6.2.1). If the delivery rate is within the permissible range, the combustion air fan has to be replaced.

Installation/Removal: as described for the drive assembly (see section 6.1.1)

Adjusting procedure: It is not possible to repair the combustion air fan. The entire drive assembly must be replaced as a unit.

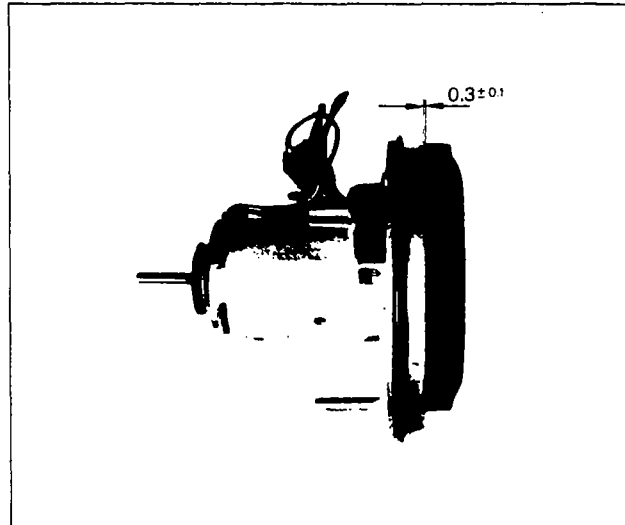

6.1.3 Combustion Air Adjusting Screw (Setscrew)

Description: The combustion air adjusting screw serves to precisely match the combustion air rate with the fuel rate delivered by the metering pump (CO₂-adjustment).

Check:

The combustion air adjusting screw is of the self-locking type. If it moves too easily, it must be replaced.

CO₂-Adjustment: After every replacement of the drive assembly or the metering pump, the CO₂-content in the exhaust gas must be measured and readjusted, if necessary.

CO₂-Setting: If the value exceeds the permissible functional range, the CO₂-setting must be adjusted to 10 - 11%, at rated voltage and full load operation, by means of the combustion air adjusting screw. A screwdriver is to be used as tool (see Fig.).

CAUTION:

The combustion air adjusting screw is factory-set to the specified CO₂-value. A correction may only be performed after the metering pump or the drive assembly has been replaced or if the combustion air fan fails to function properly.

Adjusting procedure: Prior to measuring, allow heater to run at full load for approx. 5 min. Rotation to the right: CO₂-value decreases. Rotation to the left: CO₂-value increases.

Rough adjustment: Screw in adjusting screw until its upper edge is flush with the housing.



6.1.4 Fuel Feed With Burner Mat (Vaporizer)

Description: The fuel feed forms the end section of the burner tube. The fuel is fed to the combustion chamber through the tube via the mat (different for petrol and Diesel variants).

Check: Check fuel feed section for unobstructed passage and leaks.

NOTE:

When replacing the mat, always replace sealing ring "A" too.

Use sealing compound Curil T for inserting sealing ring into the fuel feed.

CAUTION: The mat is different for petrol and Diesel type heaters. Always make sure you are using the correct type of mat!

Removal:

- Remove drive assembly (see 6.1.1).
- Loosen screw at fuel feed section (using Phillips screwdriver)
- Remove fuel feed section
- Remove mat

Installation: Installation is the reverse of removal. A new sealing ring and a new seal under the cap (wiring harness) must be installed prior to each installation. When attaching, tighten cap (wiring harness) to a torque of 1.0 Nm.

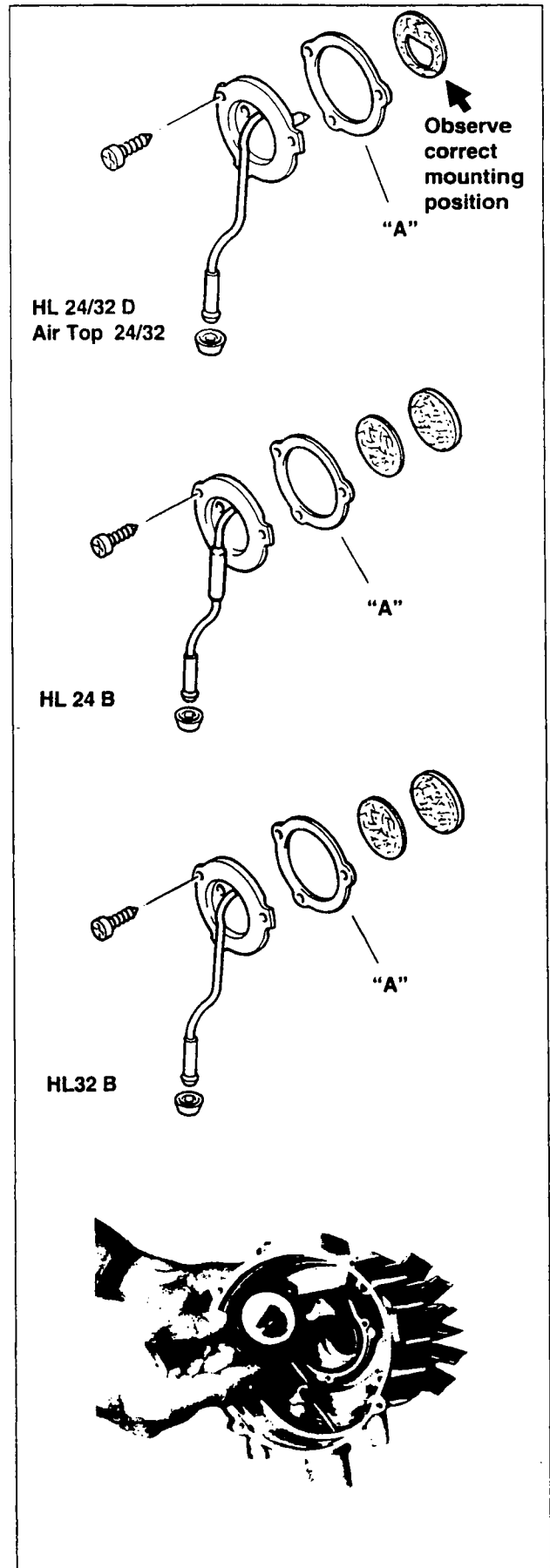

6 Components

6.1.5 Glow Plug (Not Applicable to Air Top!)

Description: The filament of the glow plug serves to ignite the fuel/air mixture upon start-up of the heater. Glow plug series resistors can be used to reduce the temperature at the filament (see section 6.4).

Removal:

- Remove cap (wiring harness) (using Phillips screwdriver)
- Remove seal from plug pins
- Unscrew glow plug (socket wrench size 19).

Check: Current draw

	Test voltage	Current draw
12 V	12 ± 0,2 V	max. 22 amps
24 V	24 ± 0,2 V	max. 15 amps

Any coked residues on the glow plug should be removed by glowing and careful cleaning. Replace glow plug, if necessary.

Note: A coked glow plug may be an indication of irregular combustion. In this case, the CO₂-setting and combustion values (see section 6.1.3) must be checked.

Installation: Installation is the reverse of removal. When screwing in the glow plugs a torque of 28 Nm is to be used. Coat threads using Copaslip. A new seal must be installed under the cap (wiring harness) prior to each installation. When attaching the cap (wiring harness), it must be tightened to a torque of 1.0 Nm.

6.1.6 Pencil-Type Glow Plug (Unique to Air Top)

Description: The pencil-type glow plug serves to ignite the fuel/air mixture upon start-up of the heater.

Removal:

- Remove cap (wiring harness) (using Phillips screwdriver)
- Remove screw (using Phillips screwdriver) and pull out pencil-type glow plug

Check: When testing the pencil-type glow plug with a digital multimeter, the following values should be obtained:

Pencil-type glow plug	12 volts (red)	24 volts (green)
Resistance at 24°C	0.29 ... 0.34 ohms	1.2 ... 1.4 ohms
Test current	< 5 mA	< 5 mA

Installation: Installation is the reverse of removal. A new seal must be installed under the cap (wiring harness) prior to each installation. When attaching the cap (wiring harness), it must be tightened to a torque of 1.0 Nm.

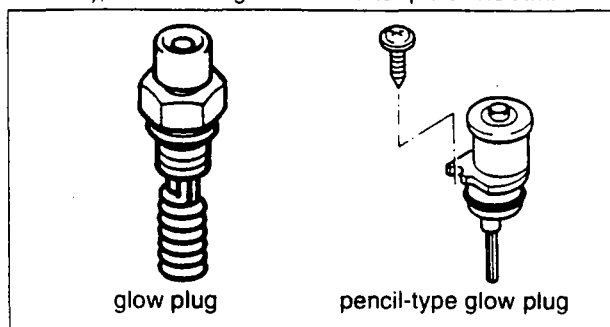

CAUTION:

The glow plug or pencil-type glow plug is to be handled with great care and to be removed from its packing only just before installation.

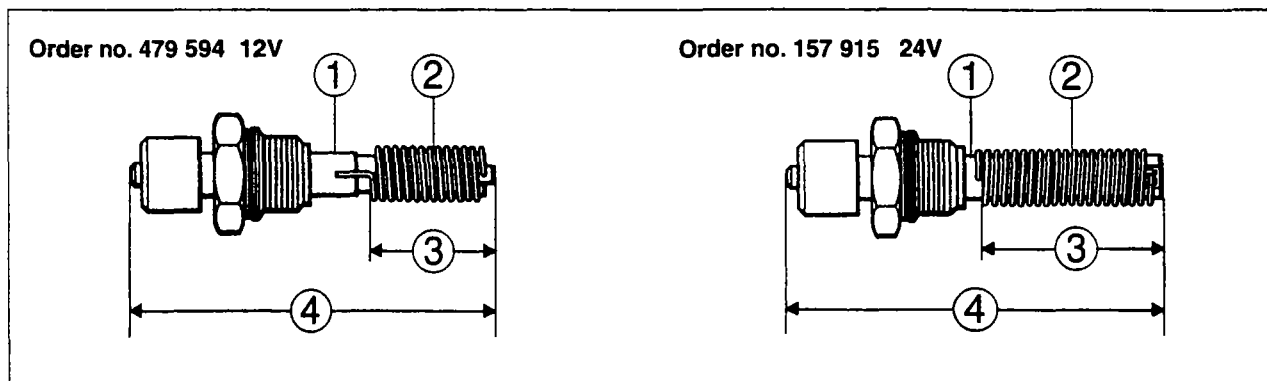

Max. voltage	Amperage	Tightening torque	Length of sleeve ①	Dia. of wire ②	Filament length ③	Overall length ④
12	20	28 Nm	ca. 7 mm	1,1 mm	ca. 20 mm	64,5 ± 1 mm
24	13,3	28 Nm	ca. 3 mm	0,8 mm	ca. 30 mm	64 ± 1 mm

6.1.7 Flame Detector

Description: The flame detector consists of a photo-transistor protected by a tube. After flames have formed the tube starts to glow so that the flame detector signals "flame".

The flame detector fulfills the following functions:

- switching off the glow plug (see section 6.1.5) or pencil-type glow plug (see section 6.1.6) after the combustion process has started,
- initiating a restarting procedure via the control unit if no flames have formed,
- switching off the heater in the case of flame failure.

Check: Switch on heater -

- a) In the event that the heater shuts down after approx. 30 sec. (with subsequent after-run cycle) a short-circuit in the electrical supply line or the flame detector exists.
- b) In the event that the heater shuts down after approx. 120 sec. although the start-up was successful and combustion was established, and if it shuts down in its 'fault lock-out' mode after a total of approx. 240 sec. (with subsequent after-run cycle) after the start-up sequence was repeated, an interruption in the electrical supply line or a defect in the flame detector exists.

Electronic after-run cycle:

HL 24/Air Top 24 = 150 sec.

HL 32/Air Top 32 = 180 sec.

Removal:

- Remove cap (wiring harness) (using Phillips screwdriver)
- Disconnect electrical connection of flame detector
- Remove locking screw from flame detector (using Phillips screwdriver)
- Remove flame detector. Any broken off fractions of the flame detector present in the combustion chamber can remain there

Repair: It is not possible to repair the flame detector; it must be replaced as a complete unit.

Installation: Whenever a flame detector is installed, the O-ring seal must be pressed onto the tip of the flame detector (coat O-ring seal with Copaslip). Prior to each installation, a new seal must be installed under the cap (wiring harness). Subsequently, the cap (wiring harness) must be reinstalled (tightening torque 1.0 Nm)

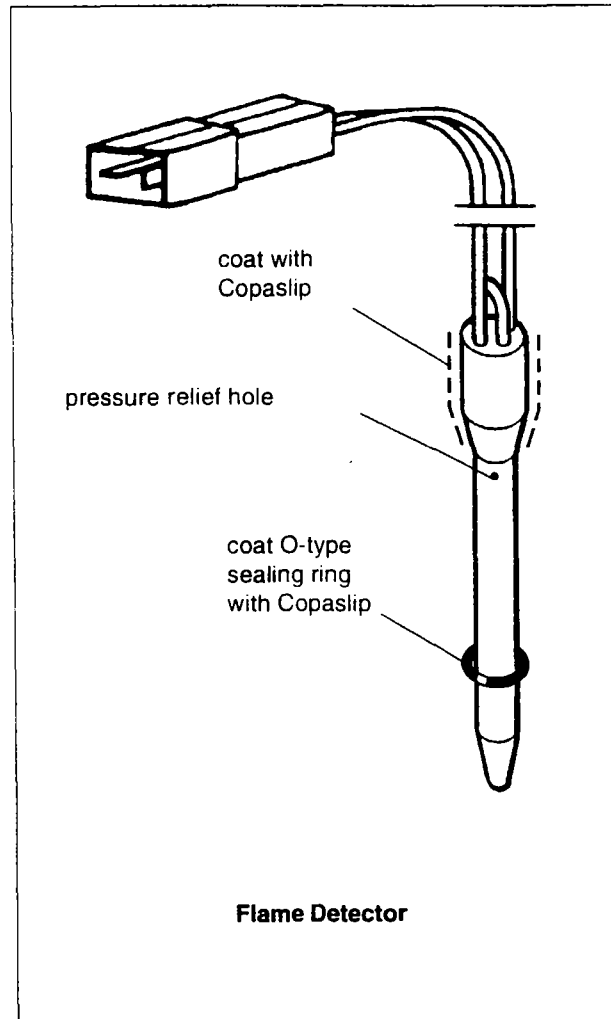

6 Components

6.1.8 Temperature Limiter and Safety Switch

6.1.8.1 Temperature Limiter

Description: The temperature limiter protects the heater from excessive operating temperatures. When the permissible temperature is exceeded, the temperature limiter interrupts the electric supply to the metering pump. The heater shuts down in its 'fault lock-out mode' due to flame failure.

Check: After having been reset manually, the temperature limiter is closed in its "cold" state (electrical continuity existing). With the temperature rising, its contacts open at $170 \pm 9^{\circ}\text{C}$; it is not self-resetting.

Removal:

- Remove cap (wiring harness) (using Phillips screwdriver)
- Disconnect plugs of motor, safety switch, temperature limiter and flame detector
- Remove upper housing half (using Phillips screwdriver)
- Unscrew temperature limiter (using Phillips screwdriver)
- Remove rubber grommet from housing

Repair: It is not possible to repair the temperature limiter; it must be replaced as a complete unit.

Installation: Installation is the reverse of removal. Complete electrical connection according to the wiring diagram. Replace the seal under the cap (wiring harness) when so doing. When attaching the cap (wiring harness) a torque of 1.0 Nm is to be used.

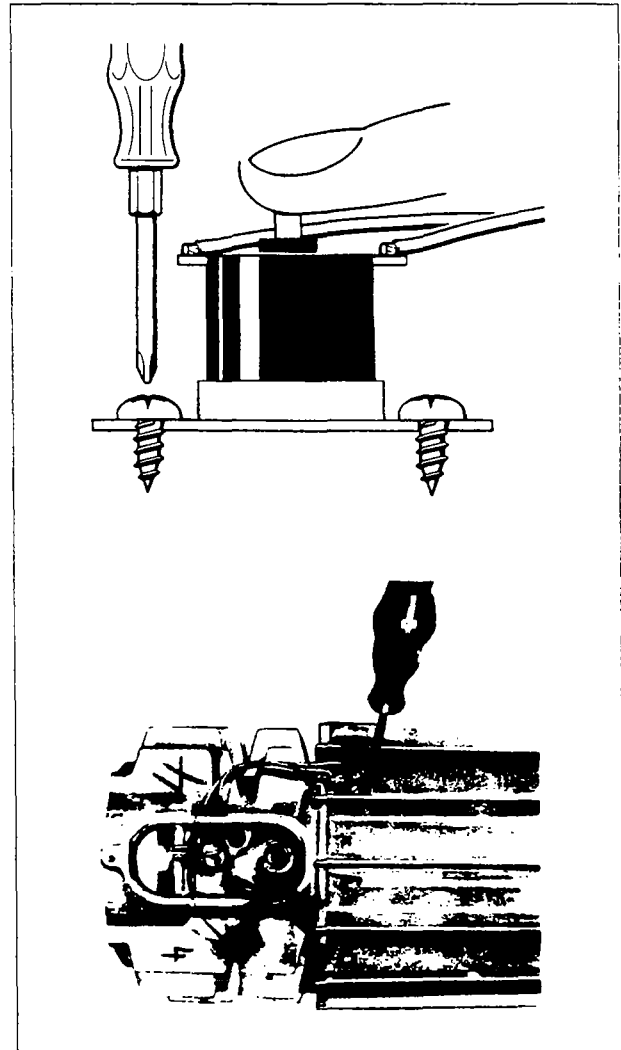

6.1.8.2 Safety Switch

Description: The switch shuts down the metering pump and thus the heater if the heater is not properly secured to its support.

Check: Check for electrical continuity.

Removal:

- Remove cap (wiring harness) (using Phillips screwdriver)
- Disconnect plugs of motor, safety switch, temperature limiter and flame detector
- Remove covers (on inlet and outlet sides)
- Remove lockwasher and fan wheel from motor shaft
- Loosen motor cover (using Phillips screwdriver)
- Loosen switch in motor cover

Repair: It is not possible to repair the safety switch; it must be replaced as a complete unit.

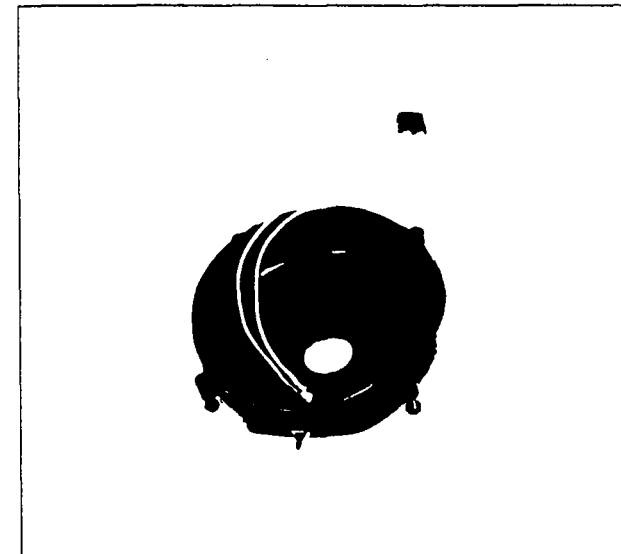

Installation: Installation is the reverse of removal. Complete electrical connection according to the wiring diagram. Replace the seal under the cap (wiring harness) prior to each installation. When attaching the cap (wiring harness) a torque of 1.0 Nm is to be applied.

6.1.9 Heat Exchanger

Description: The heat exchange between the heat produced by combustion and the heating air takes place in the heat exchanger.

Removal:

- Remove drive assembly (see section 6.1.1)
- Loosen screws securing temperature limiter; remove radiation protection (1); loosen screws on heat exchanger (using socket head wrench, width across: 8), and remove heat exchanger.

Check: All contaminated parts must be cleaned. Be sure to also clean the exhaust connection piece and deflection point (A). Install a new mat prior to reinstallation (see section 6.1.4) and clean burner tube (see section 6.1.10).

Installation: Installation is the reverse of removal. Tightening torque of screws is 4.5 Nm. A new O-type sealing ring 118x2 must be installed between housing and heat exchanger (only genuine Webasto replacement parts to be used). A new seal must be installed under the cap (wiring harness) prior to each installation.

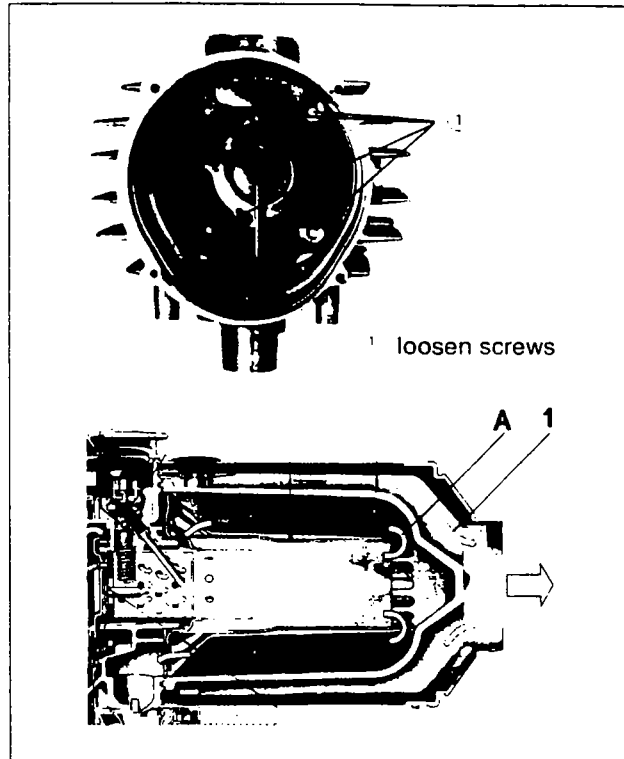

6.1.10 Combustion Chamber (Burner Tube)

Description: In the combustion chamber the combustion of the fuel ignited by the glow plug (pencil-type glow plug in Air Top units) takes place.

Removal:

- Remove heat exchanger (see section 6.1.1)
- Remove glow plug or pencil-type glow plug and flame detector (see sections 6.1.5 and 6.1.6)
- Loosen 4 screws on the housing (using Phillips screwdriver) and remove combustion chamber (burner tube)

Check: Inspect combustion chamber for damage (cracks) and security. Remove contaminations and coke deposits.

Installation: Installation is the reverse of removal. Replace mat (see section 6.1.4).

HL 24 B order no. 203 23A
HL 24 D order no. 112 546

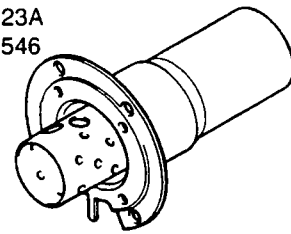

HL 32 B/D order no. 468 71G

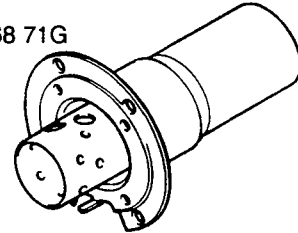

Air Top 24 order no. 267 14A

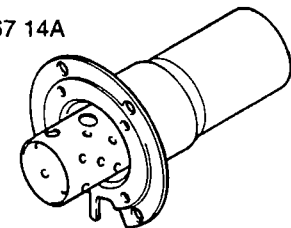

Air Top 32 order no. 264 53A

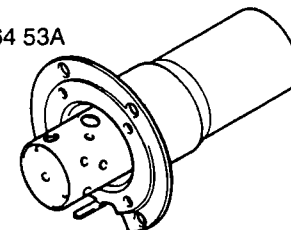

6 Components

6.2 Fuel System

6.2.1 Metering Pump

Description: The metering pump is designed to deliver and meter the fuel for the heater and serves as shut-off device at the same time. It operates on the principle of an electromagnetic reciprocating pump.

Cycling frequency within the operating voltage range:

	HL24 B	HL24 D	Air Top 24 B	Air Top 24 D
FL	1.39 Hz	1.22 Hz	1.39 Hz	1.22 Hz
PL	0.69 Hz	0.61 Hz	0.69 Hz	0.61 Hz

	HL32 B	HL32 D	Air Top 32 B	Air Top 32 D
FL	1.85 Hz	1.63 Hz	1.85 Hz	1.63 Hz
PL	0.925 Hz	0.815 Hz	0.925 Hz	0.815 Hz

Check: Internal resistance

	HL24 B/D Air Top 24 B/D	HL32 B/D Air Top 32 B/D
12 V	10 ohms	10 ohms
24 V	40 ohms	40 ohms

NOTE:

Delivery rate V (ml) of metering pump after 180 sec. pumping time as a function of the input voltage U_E (V) of the control unit.. $T_u = + 20 \pm 2 (^{\circ}\text{C})$

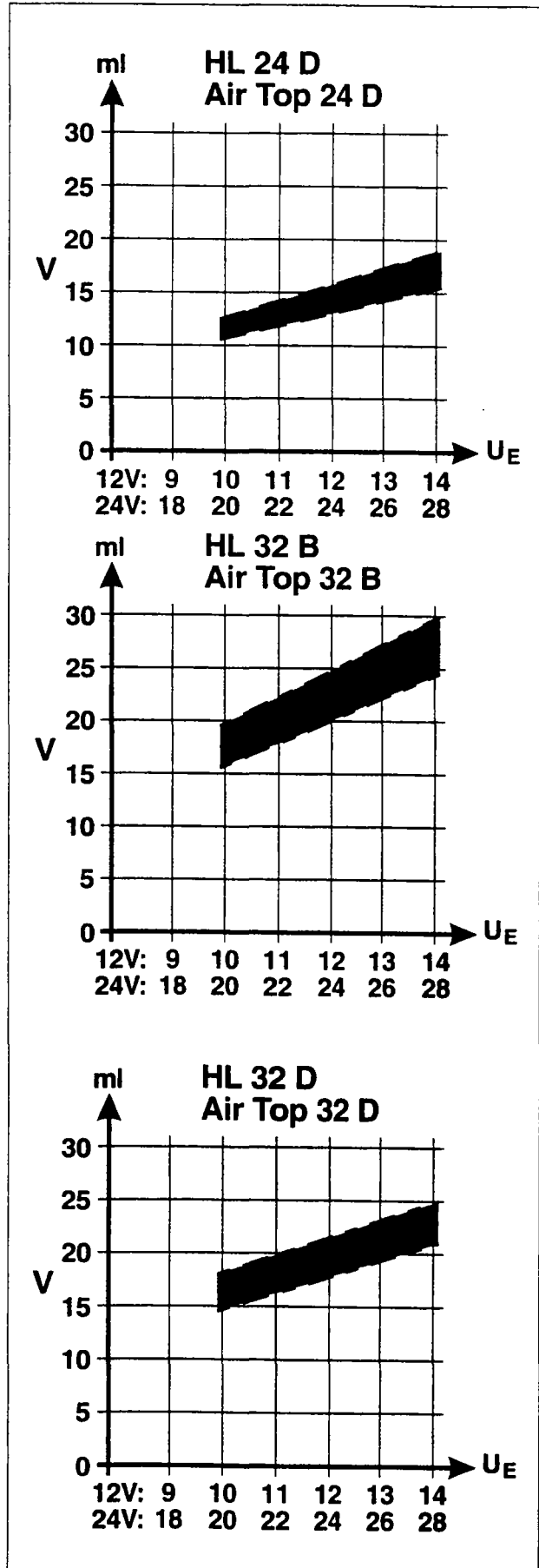
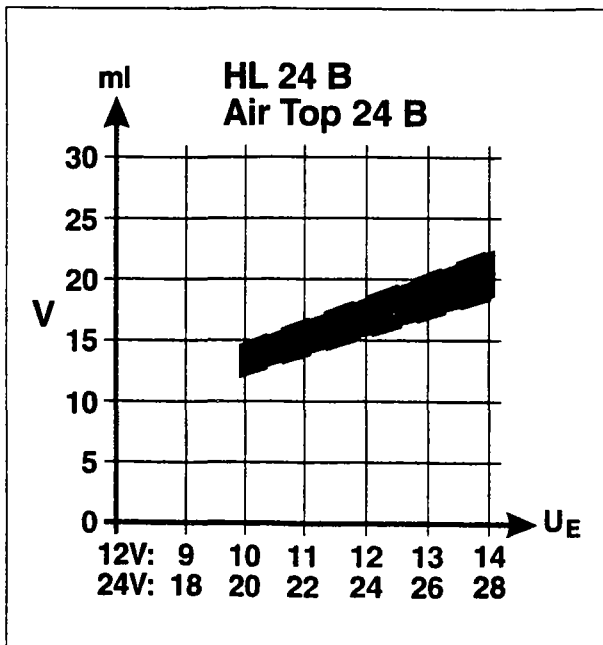

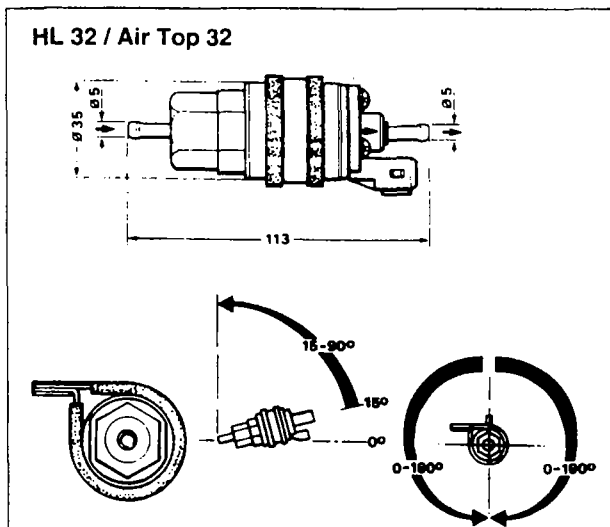
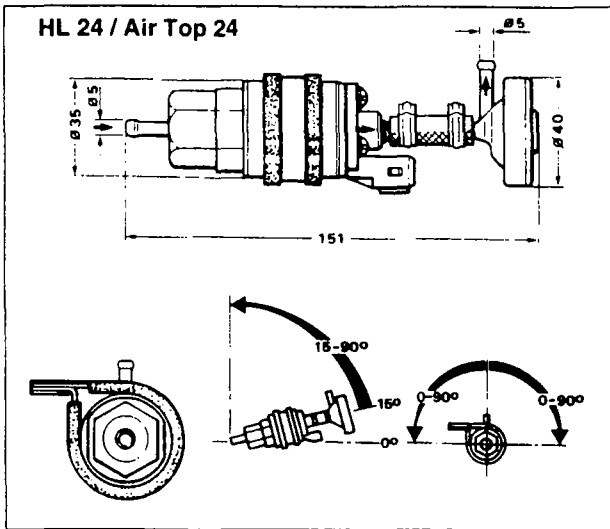

Removal/Installation:

After detaching the electrical connections, hose clamps and hoses as well as the clamping clip, the metering pump can be removed. Installation is the reverse of removal.

Check:

The delivery capacity of the fuel metering pump can be checked by measuring the fuel pump output:

- 1) Pull fuel hose off heater and hold it into a measuring cylinder or, in confined areas, slip it onto a glass graduate (measuring volume 100 ml).
- 2) Switch on heater

Applies to HL 24/32 B/D with SG 1561 and SG 1561 GT
After 120 sec. the heater automatically shuts down and the start-up sequence is repeated.

Applies to Air Top 24/32 B/D with SG 1561 GS (order no. 241 89A)

After 115 sec. the heater automatically shuts down and the start-up sequence is repeated.

Independent of the type of electronic control unit used, fuel is delivered for 90 sec. during each start-

up procedure.

Starting and restarting time amounts to 2 x 90 sec. Repeat the procedure until fuel emerges from the fuel hose.

NOTE:

Measure the voltage at the control unit during the measuring procedure:

- HL 24/32 B/D contacts B1(+) and B2(-)
- Air Top 24/32 B/D contacts C6(+) and C1(-)

- 3) To measure the fuel quantity, switch the heater on again and measure the increase in fuel over the 2 x 90 sec. period. Shut-down is effected automatically.
- 4) To evaluate the data thus determined, enter them into the appropriate chart. The intersecting point must lie within the hatched area.

NOTE (applicable only to HL24 B/D and Air Top 24 B/D): In the case of excessive delivery or heavily pulsating combustion noises, replace only the diaphragm damper as a first step.

The hose between metering pump and diaphragm damper must not be extended in length.

Repair: A defective metering pump must be replaced. After the replacement of the metering pump the CO₂ content must be measured and readjusted, if necessary (see section 6.1.3).

6.2.2 Fuel System

The permissible diameter of tubes leading from the tank to the metering pump is max. 3 mm, that of tubes leading from the metering pump to the heater 2 mm.

permissible fuel feed height H(m)	at max. permissible overpressure (bar) in the fuel line
0.00	1.5
1.25	1.4
2.50	1.3
3.75	1.2
5.00	1.1
6.25	1.0
7.50	0.9
8.75	0.8
10.00	0.7
permissible fuel suction height S(m)	at max. permissible over- pressure (bar) in fuel tank
0.00 (P + D)*	- 0.15 (P + D)*
0.50 (P + D)*	- 0.11 (P+D)*
1.00 (D)*	- 0.07 (D)*

* B = petrol
D = Diesel

6 Components

6.2.3 Fuel Pickup

Description: The fuel pickup serves to extract the fuel and to separate any bubbles that may be present in the fuel. It must on no account be replaced with normal "T" fittings. Owing to the high flow velocity prevailing in the branch pieces of normal "T" fittings, there is an increased danger of gas bubbles being fed to the metering pump.

Note: The fuel tank must be sufficiently ventilated (e.g. at the filler cap).

6.2.4 Fuel Filter

Description: The filter may be installed in the fuel intake line between tank and metering pump. If the fuel is likely to be severely contaminated, the filter must be retrofitted.

Check: Observe direction of flow. In the case of contamination, replace filter completely (only Webasto filter, order no. 487 171 to be used, see Installation Instructions and Spare Parts List).
Check filter housing and connections for leaks.

6.2.5 Tank Extracting Device

Description: The tank extracting device serves to draw fuel from the fuel tank. It must be installed as close to the tank as possible and leak-proof connection of the fuel line must be ensured.

The distance existing between the end of the tube and the bottom of the tank serves to prevent dirt and water from being drawn in from the tank bottom.

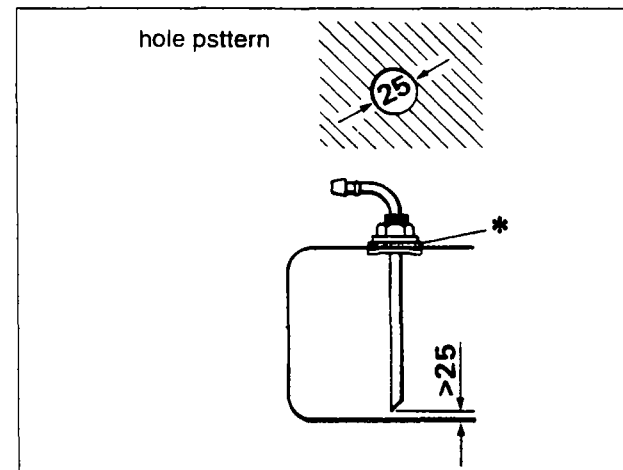
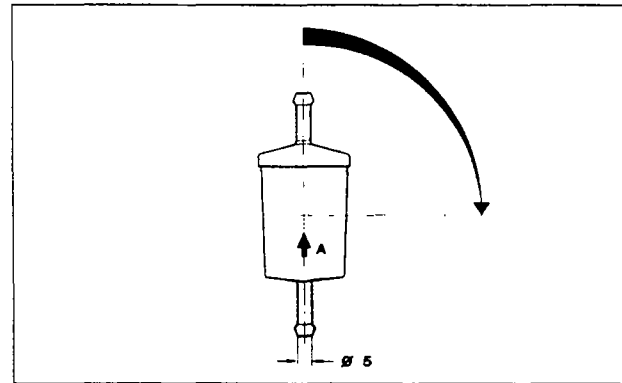
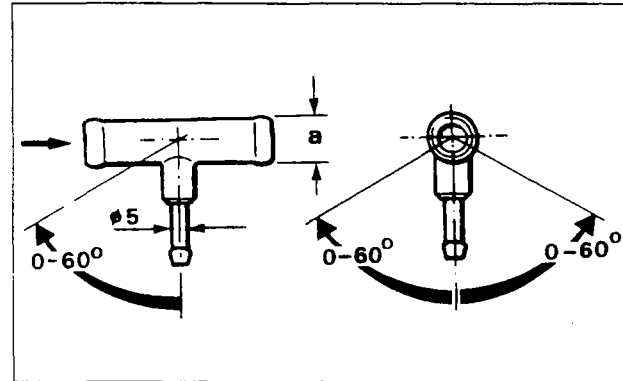

* tank extracting device only to be used with metal fuel tanks

tank extracting device Da 5.5 mm 353 205
 tank extracting device Da 8.0 mm 353 213

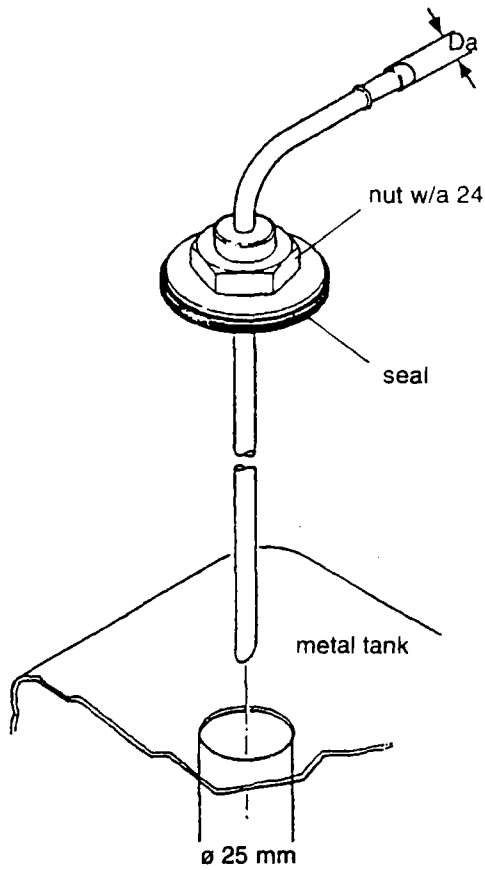

fuel extraction from metal tank using tank extracting tube

Components required for building the tank extracting device:

- 1 banjo bolt M14x15 DIN 7623 commercially available
- 1 ring-type tube piece 14x15 DIN 7642 commercially available
- 2 copper sealing rings DIN 7601 commercially available
- 1 copper tube 8 mm; 30 mm long commercially available

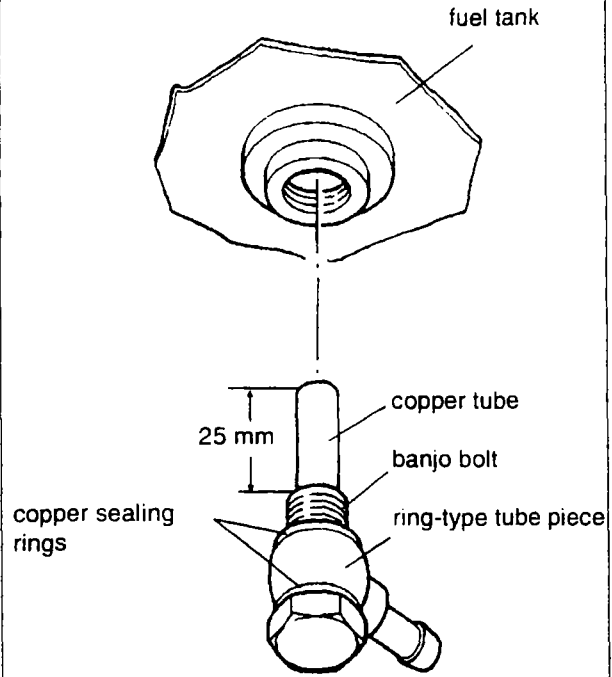

Fuel extraction via tank drain opening

tank extracting device 259 08A

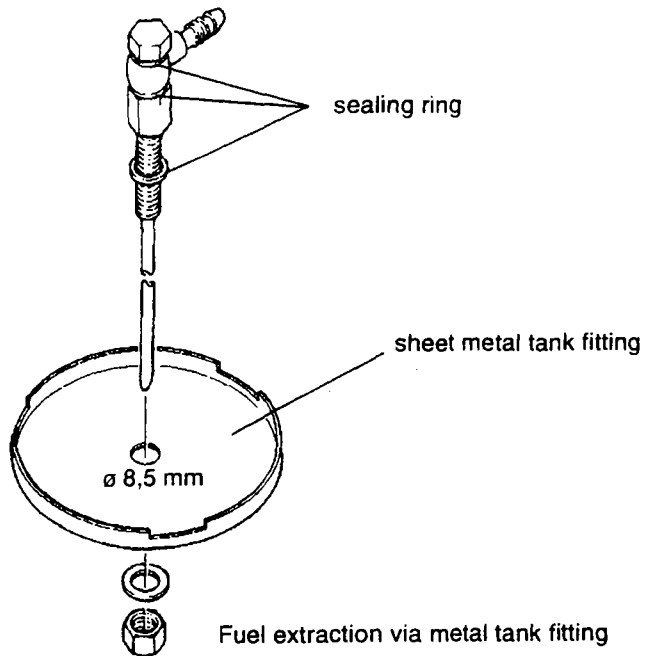

Fuel extraction via metal tank fitting

6 Components

6.3 Exhaust and Combustion Air System

6.3.1 Pressure Equalizer (Exhaust/Intake Duct)

Description: The pressure equalizer is designed for combustion air inlet and exhaust outlet and is connected to the appropriate lines.

The pressure equalizer prevents the flame in the heater from being "blown out". It prevents pressure differences between combustion air inlet and exhaust outlet.

Note: The pressure equalizer is normally only required for heaters with part load operation. For boats and ships its installation is mandatory. In the area of the outer skin of the vessel an insulating plate made of V2A steel is to be inserted.

Check: Remove dirt on and in the pressure equalizer. Ensure that passage is unobstructed. Check hose connections for security.

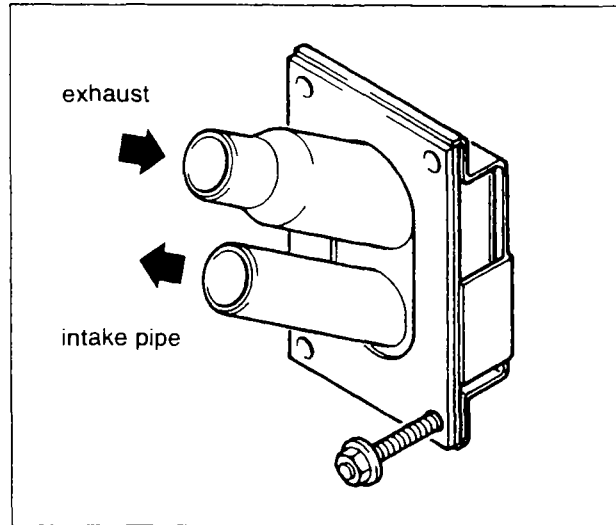

6.3.2 Exhaust Silencer

Check: Check for unobstructed passage and check CO₂-content, if necessary.

In the case of severely contaminated heat exchangers or flexible exhaust pipes the exhaust silencer must be replaced.

Note: On boats and ships, insulation of the exhaust silencer is only permitted using insulating tape (order no. 428 132, by the meter, or 443 247, on 25 m-rolls). Insulation must be applied in at least 3 layers.

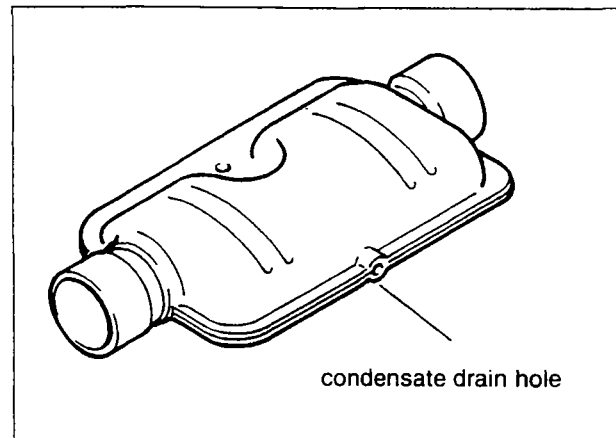

6.3.3 Flexible Exhaust Pipe

Check: Check for contamination, damage and restriction of cross-sectional area (e.g. due to accumulated condensation water, sharp bends). The maximum permissible pipe lengths specified in the Installation Instructions are to be adhered to.

Note: On boats and ships, insulation of the exhaust pipe is only permitted using insulating tape (order no. 428 132, by the meter, or 443 247, on 25 m-rolls). Insulation must be applied in at least 3 layers.

6.3.4 Combustion Air Pipe

Check: Check for unobstructed passage. The opening must not point in upward direction so as to prevent the ingress of water.

Note: The maximum permissible pipe lengths specified in the Installation Instructions are to be adhered to.

The combustion air should be extracted from a dust-free area, if possible.

6.4 Electrical Parts

6.4.1 Electronic Control Unit

Description: Upon start-up, the control unit takes over the complete control of the functional sequence of the heater operation (see section 5 "Functional Description"). For this purpose, it evaluates the signals received from the flame detector as well as the full load/part load functions of room thermostats or switches.

Check: Checking the control units (SG 1561 and SG 1561 GT) can only be accomplished by means of the Webasto testing device (see section 7.2.1).

Repair: Any defective control unit must be replaced as a complete unit.

Note: The components such as control unit, pulse-controlled glow plug relay and part load resistor for the 12 V system are identified by a red label, those components for the 24 V systems by a green label.

For HL24/32 (petrol) and D (Diesel) heaters the following electronic control units are used:

Control unit	Order No.	
	12 V	24 V
SG 1561	482 110	482 129
SG 1561 GT*	156 97	156 98
SG 1547 (TRS)		105 604
SG 1561 with adapter wiring harness	462 381	462 403

* GT = integrated pulse-controlled glow plug relay

The petrol and Diesel fuelled Air Top 24/32 heaters (24 V) are equipped with the control unit SG 1561 GS (order no. 241 89A).

For TRS units fitted with SG 1561 and SG 1561 GT, the SG 1547 is required in addition.

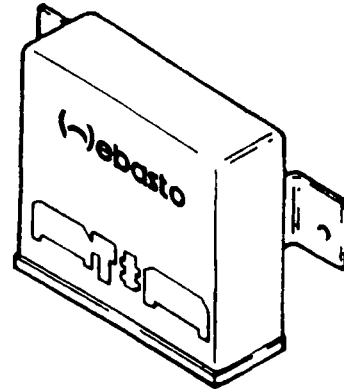

HL 24/32:
SG 1561
SG 1561 GT

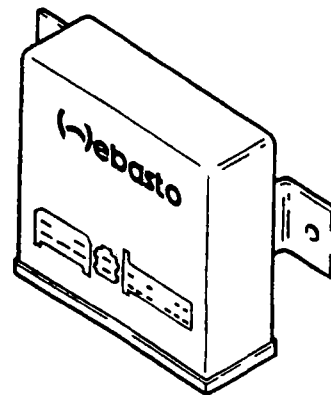

Air Top 24/32:
SG 1561 GS
order no. 241 89A

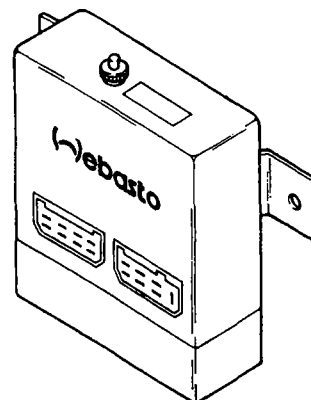

SG 1547 TRS

6 Components

6.4.2 Resistor (Part Load)

Description: The resistor reduces the motor speed during part load operation.

Check:

	HL24 B/D	HL32 B/D
12 V	5.1 ohms	3.9 ohms
24 V	20 ohms	13 ohms

Removal:

- Remove drive assembly (see 6.1.1)
- Unscrew resistor (using Phillips screwdriver)
- Remove two cables of the resistor directly at the resistor

Repair: It is not possible to repair the resistor; it must be replaced as a complete unit.

Installation: Solder cable onto resistor. The remainder of the installation procedure is the reverse of removal.

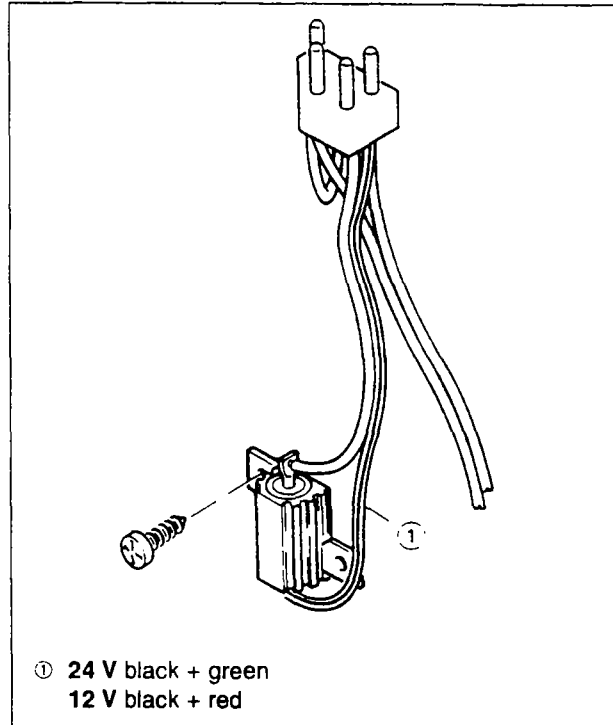

6.4.3 Glow Plug Series Resistor 0.61 ohms (optional)

Description: On 24 V heaters without pulse-controlled glow plug operation, a glow plug series resistor is required when a 12 V glow plug with 0.61 ohms is used.

Adjustment:

- Remove perforated plate
- Loosen screw at pick-off and displace pick-off

NOTE:

The glow plug series resistor can only be replaced with a pulse-controlled glow plug relay and a 24 V glow plug.

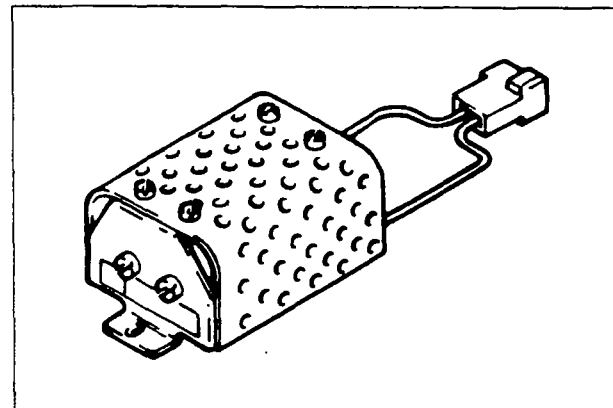

6.4.4 Glow Plug Series Resistor 0.27 ohms (optional)

Description: The glow plug series resistor reduces the temperature at the glow filament and thus increases the life of the 24 V glow plug.

CAUTION:

The temperature of the resistor can reach up to 160°C. When installing the resistor make sure that it is installed in a sufficiently ventilated area and that no inflammable or temperature-sensitive parts are in the vicinity.

To be able to conduct the heat, the holder of the resistor must be directly attached to metal. If this is not possible, this is to be accomplished by heat-conducting distance pieces.

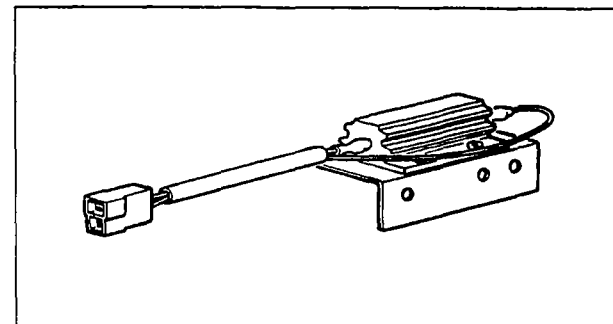

6.4.5 Pulse-Controlled Glow Plug Relay (only in conjunction with SG 1561) (optional)

Description: The relay for the pulse-controlled glow plug serves to protect the glow plug from electrical overloads. Current supply is kept constant throughout a voltage range from 11.5 to 14 V (23 - 28 V), at a pulse rate of 0.8 Hz with switching pulses of different duration.

Electrical connection

(conversion/retrofitting)

- Checking the 2-pole connection for pulse-controlled glow plug relay.
- Cable colors yellow and white: no check required.
- Cable colors: 2x yellow: continuity check to be performed, replace cable if necessary and repeat test.
- For connections refer to wiring diagram.

NOTE:

For units equipped with battery isolator switch the brown earth wire (5) is to be connected to the negative pole of the battery.

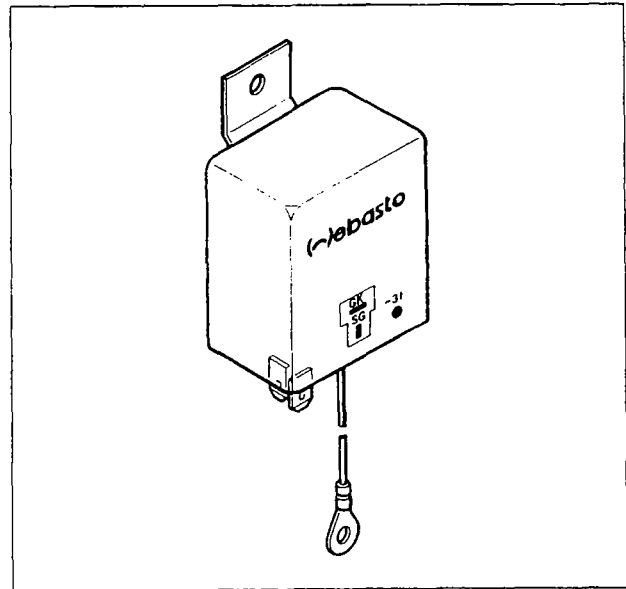

6 Components

6.4.6 Wiring Harness HL 24/32

Description: The wiring harness consists of

- wiring harness 1 = heater - control unit
- wiring harness 2 = control unit - Timer/switch,
room thermostat, fuse box
- wiring harness 3 = control unit - metering pump

The heaters are supplied with a standard wiring harness. On HL24/32 D (Diesel) heaters the standard-type wiring harness is used unchanged. On HL24/32 B (petrol) heaters the brown wire (br) must be removed from the connector cage C1, see wiring diagram.

CAUTION:

Depending on the control unit used, one of the following components may have to be fitted to the yellow wire (ge)!

		Heater	
Control unit	yellow (ge) wire	12 V	24 V
SG 1561 GT	jumper	X	X
SG 1561	pulse-controlled glow plug relay A4	X	X
SG1561 + SG 1547 (TRS)	pulse-controlled glow plug relay A4	X	X
SG 1561 GT + SG 15476 (TRS)	jumper	X	X
SG 1561	glow plug series resistor R1 + 12 V glow plug		X

Check / Repair: If only the cap of the wiring harness is damaged, it can be replaced with the "repair wiring harness" (L = 250 mm) (4). The connection to the wiring harness already installed can be established using the supplied hardware.

NOTE:

The adapter wiring harness (5) is only installed in combination with control units order no. 462 381 (12 V) and order no. 462 403 (24 V).

Refer to wiring diagram on page 37.

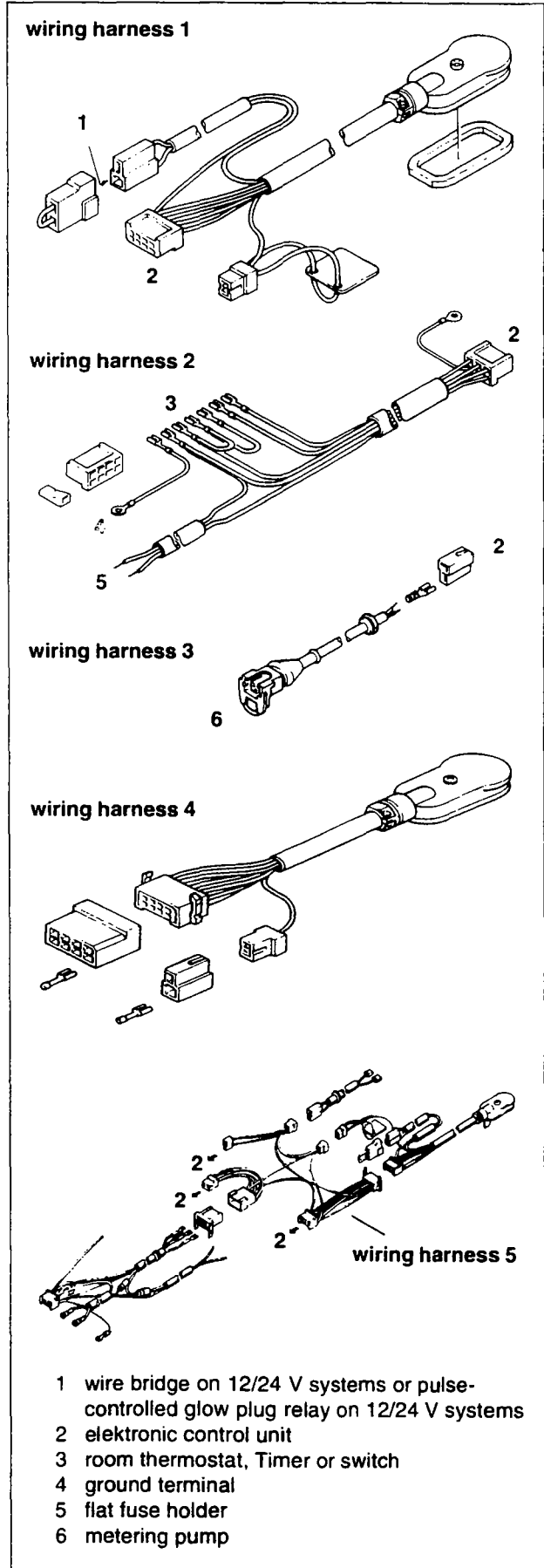

6.4.7 Wiring Harness Air Top 24/32

Description: The wiring harness consists of

wiring harness 1 = heater - control unit

wiring harness 2 = control unit - room thermostat,
Timer/switch, flat fuse holder

wiring harness 3 = control unit - metering pump

The heaters are supplied with a standard wiring harness. On Air Top 24/32 D (Diesel) heaters the standard-type wiring harness is used unchanged. On Air Top 24/32 B (petrol) heaters the brown wire (br) must be removed from the connector cage C14, see wiring diagram on page 42.

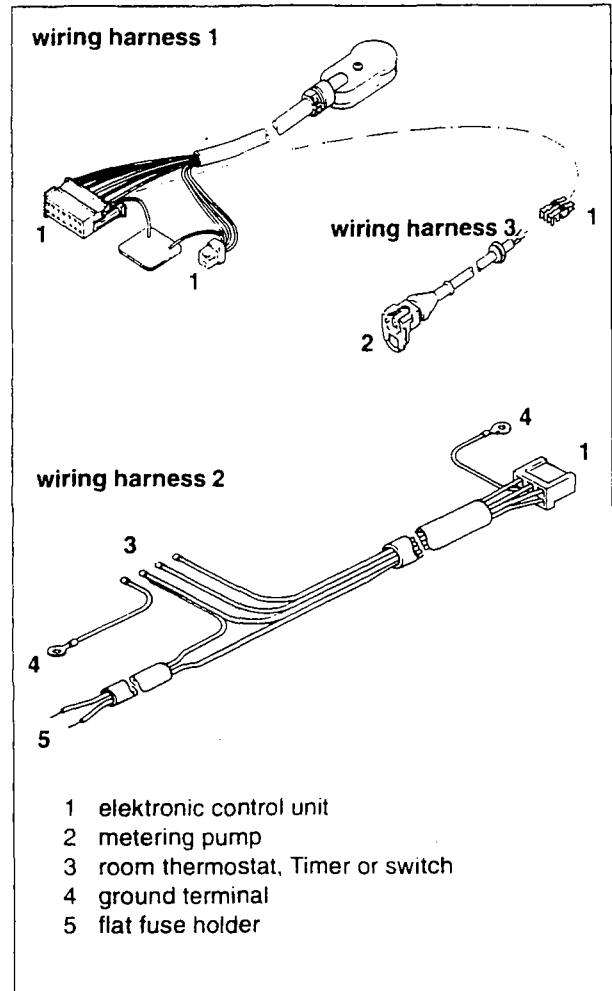

6 Components

6.4.8 Conversion Kit

Description: The TRS conversion kit consists of

- control unit 1547 TRS (1) (in addition to SG 1561 or SG 1561 GT)
- solenoid valve 24 V (2)
- preformed tube (3)
- electr. and mech. hardware
- 2 labels (4) and (5).

The conversion kit serves to convert the HL24/32 heaters for use in vehicles carrying hazardous materials.

Refer to "TRS-version" wiring diagram on page 41.

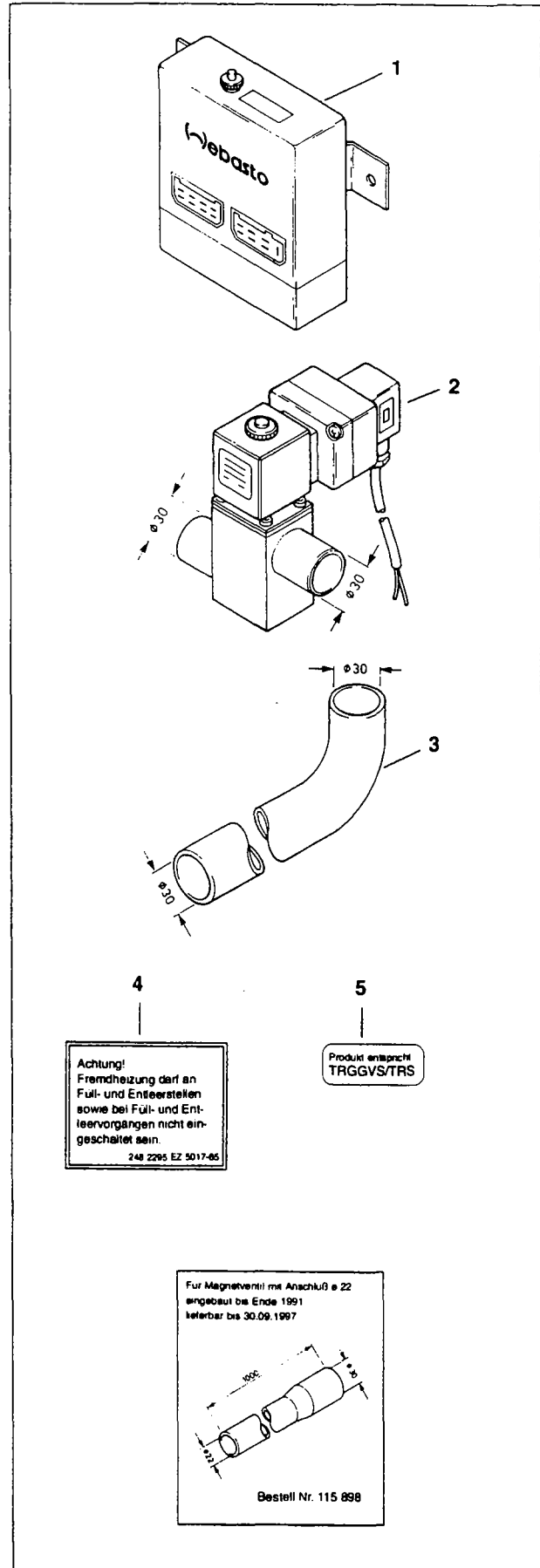

7 Notes on Repair and Disassembly

7.1 General Important Repair Instructions

7.1.1 Installation and Removal of Heater

Before proceeding with any work on the heater, always disconnect the main cable from the vehicle battery to interrupt the battery main power supply. The **battery main power** must not be cut off while the heater is in operation owing to the **danger of the heater overheating** and the subsequent activation of the temperature limiter. If extensive repair work is to be performed on the heater, it is useful to remove the heater completely.

Remove the heater by removing the cap/wiring harness (using Phillips screwdriver) and loosening two M6 screws (wrench size 5, tightening torque 12 Nm, angled screwdriver for Allen screws). The heater holder thus remains rigidly installed in the vehicle.

CAUTION:

When reassembling the heater, always use new seals and gaskets.

The two seals provided at the combustion air intake and the exhaust outlet connections must be replaced prior to each reinstallation of the heater. Should it be necessary to remove the holder, **the gasket under the holder must be replaced with a new one as well.** This gasket serves to compensate for a groove max. 4 mm deep and/or a ridge max. 3 mm high. The safety switch interrupts heater operation if the heater does not rest squarely on its holder (support)!

In the case of repairs involving a modification of the installation, the heater installation instructions must be observed.

7.1.2 Work on the Vehicle

The electronic control unit should not be exposed to temperatures greater than +85°C (storage temperature) (e.g. when carrying out paintwork on the vehicle).

7.1.3 Test Run of the Heater

The heater must not be operated in enclosed spaces, such as garages or workshops without adequate exhaust extraction, not even if operating times are preset by a Timer.

Allow heater to run for approx. 5 min., measure CO₂ content and readjust if tolerances are exceeded.

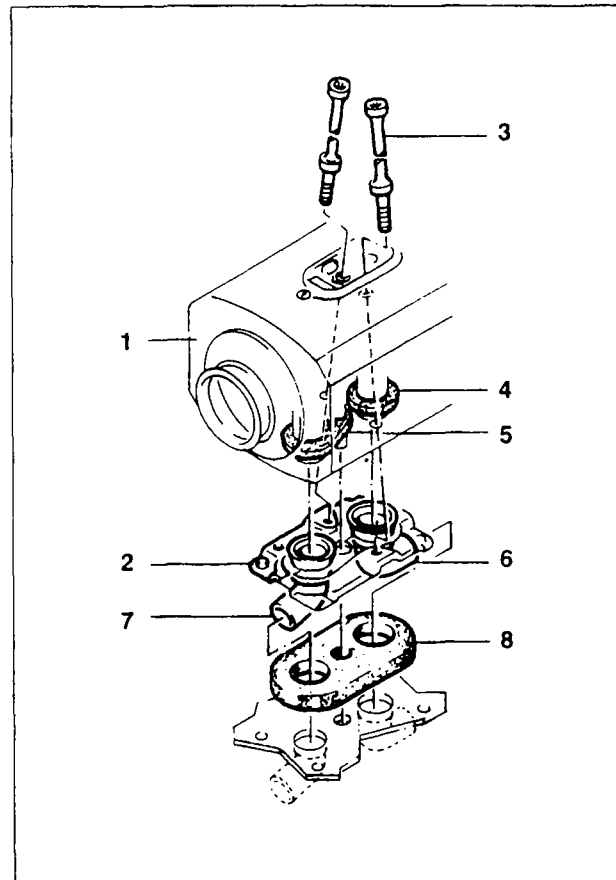

- 1 heater
- 2 holder (support)
- 3 shaft screw M6 (qty. of 2, tightening torque 12 Nm)
- 4 seal
- 5 seal
- 6 elbow
- 7 intake connector
- 8 gasket

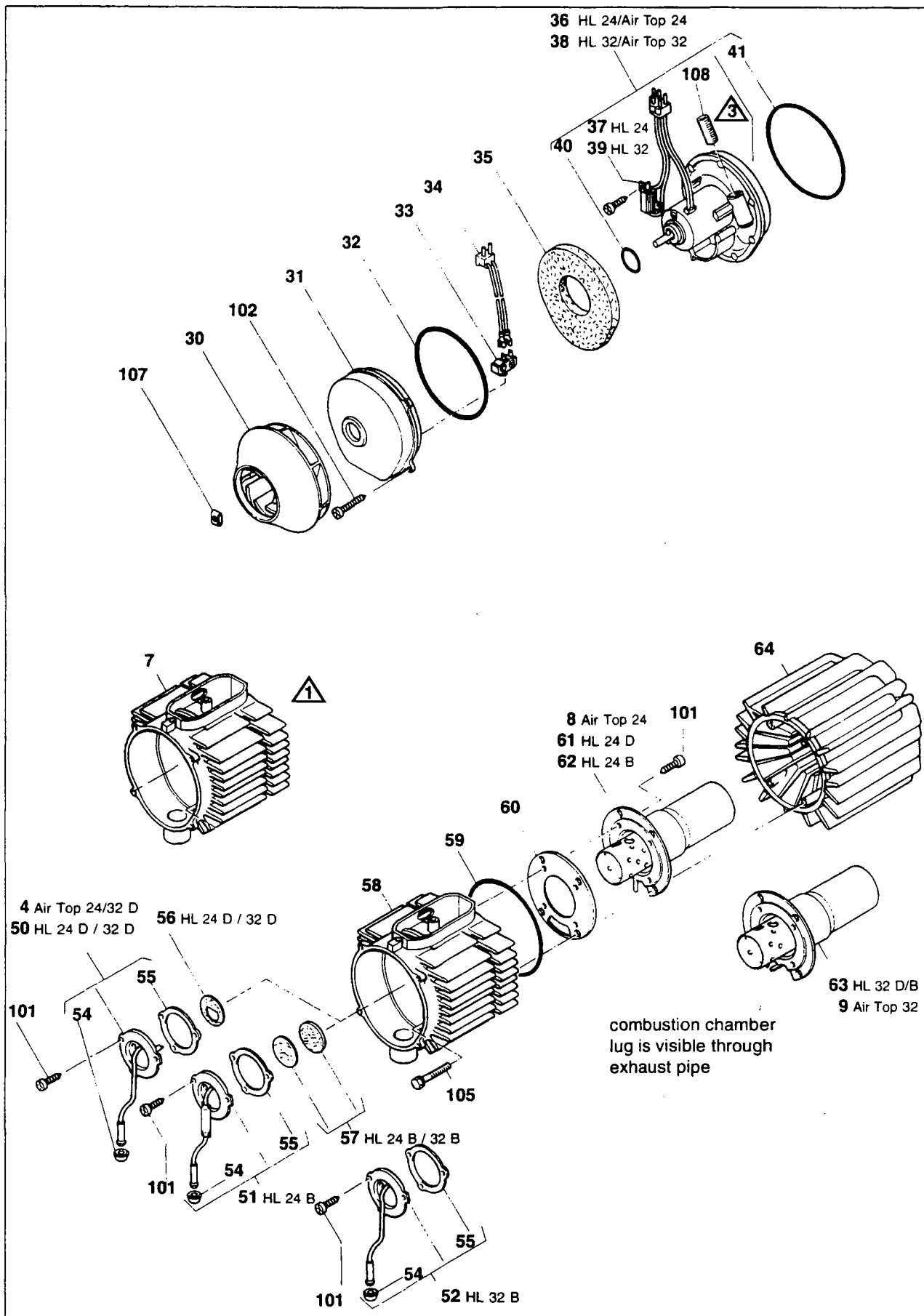

7 Notes on Repair and Disassembly

7.3 Tools and Measuring Instruments

7.3.1 Testing Device

Description: The testing device can be used for:

- the overall check of HL 24/32 B and HL 24/32 D heaters, 12 and 24 V versions, and Air Top 24/32, installed in the vehicle,
- the separate check of the control unit, 12 and 24 V versions, installed in the vehicle

Testing device (bag):

without adapter wiring harness 205 95A

Testing device: 157 49A

Adapter wiring harness for HL 24/32

with SG 1561 and SG 1561 GT 250 97A

Adapter wiring harness for Air Top 18/24/32

with SG 1561 GS 307 60A

Can be ordered from:

Webasto

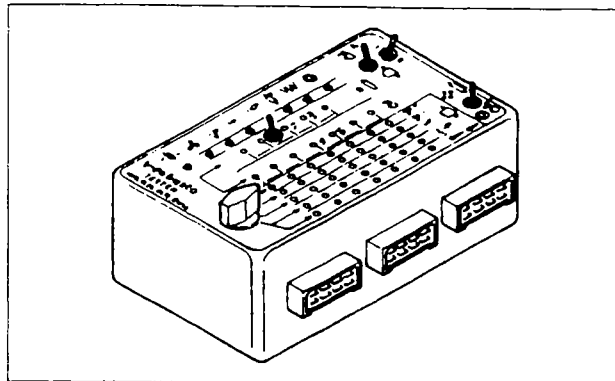

7.3.2 Glow Plug Wrench

Description: Pipe wrench, wrench opening 19 (commercially available) or extra long socket wrench (19 mm/1/2") and torque wrench (0.5 to 50 Nm).

7.3.3 Measuring Tools and Instruments

CO₂-indicator for measuring the CO₂ content in the exhaust gas:

H. Maihak AG
Semperstr. 26-38
D-22303 Hamburg

Hans G. Werner & Co.
Forststr. 60
D-70176 Stuttgart

Bruno Ihrig
Kronbergerstr. 9-11
D-63110 Rodgau

CO₂-analyzer AD 50

Wöma GmbH+Co. KG
Postfach 105313
D-70046 Stuttgart

Soot analyzer for measuring the soot content in the exhaust gas:

Hans G. Werner & Co.
Forststr. 60
D-70176 Stuttgart

Vibration-type tachometer for measuring the speed of the heater's motor:

Dr. E. Horn GmbH
Postfach 1162 D-71094 Schönaich
Telefon 07031 / 55 02 01

Multimeter to measure voltage and current:

Commercially available

Assembly pliers type CLIC 201 for the mounting of hose clamps between metering pump and diaphragm damper (see 6.2.1):

Webasto,
order no. 104 602 straight
order no. 104 606 bent

8 Maintenance of the Heater

The heater should be checked annually, preferably prior to the heating season commencing (when the

heater is used frequently due to weather conditions).

Inspection/Maintenance Work (for Troubleshooting see chapter 4)	Important Notes	Inspection Results		Measured Values, Repair Work Performed
		o.k.	not o.k.	
1. Electrical System a) Loosen all electrical connections, check for oxidation, apply contact spray and reconnect. b) Inspect fuses for oxidation or contact resistance.	Use suitable contact spray, e.g. special contact spray (order no. 101 322)	<input type="checkbox"/>	<input type="checkbox"/>	
2. Heat Exchanger a) Check for signs of leakage. b) Clean outside of heater; prevent ingress of water. NOTE: The heat exchanger must be replaced after 10 years.	Determine cause of overheating, if necessary; check temperature limiter.	<input type="checkbox"/>	<input type="checkbox"/>	
3. Fuel System a) Perform functional check of metering pump. b) Check fuel lines and connections for tightness. c) Check fuel filter and replace, if necessary.	Ensure leakproof fuel line connections! Retighten screw connections and hose clamps.	<input type="checkbox"/>	<input type="checkbox"/>	
4. Burner a) Inspect inside of housing for fuel accumulation caused by leakage. b) Replace burner, if necessary. c) Check flame detector for damage. Check glow plug/pencil-type glow plug.	CAUTION: There is a fire hazard when burner is opened. Burners are different in "Petrol" and "Diesel" variants.	<input type="checkbox"/>	<input type="checkbox"/>	
5. Combustion Air and Exhaust Systems a) Check fuel lines for unobstructed passage and clean, if necessary. b) Check exhaust pipe for unobstructed passage and clean, if necessary. c) Remove burner tube from heat exchanger, check both parts for damage and contamination and clean or replace, as required. d) Reconnect electrical connections		<input type="checkbox"/>	<input type="checkbox"/>	
6. Functional Check a) Check heater for proper functioning. b) Check CO ₂ -content in exhaust gas and readjust, if necessary.	After a heating operation of min. 10 minutes.	<input type="checkbox"/>	<input type="checkbox"/>	

9 Wiring diagrams

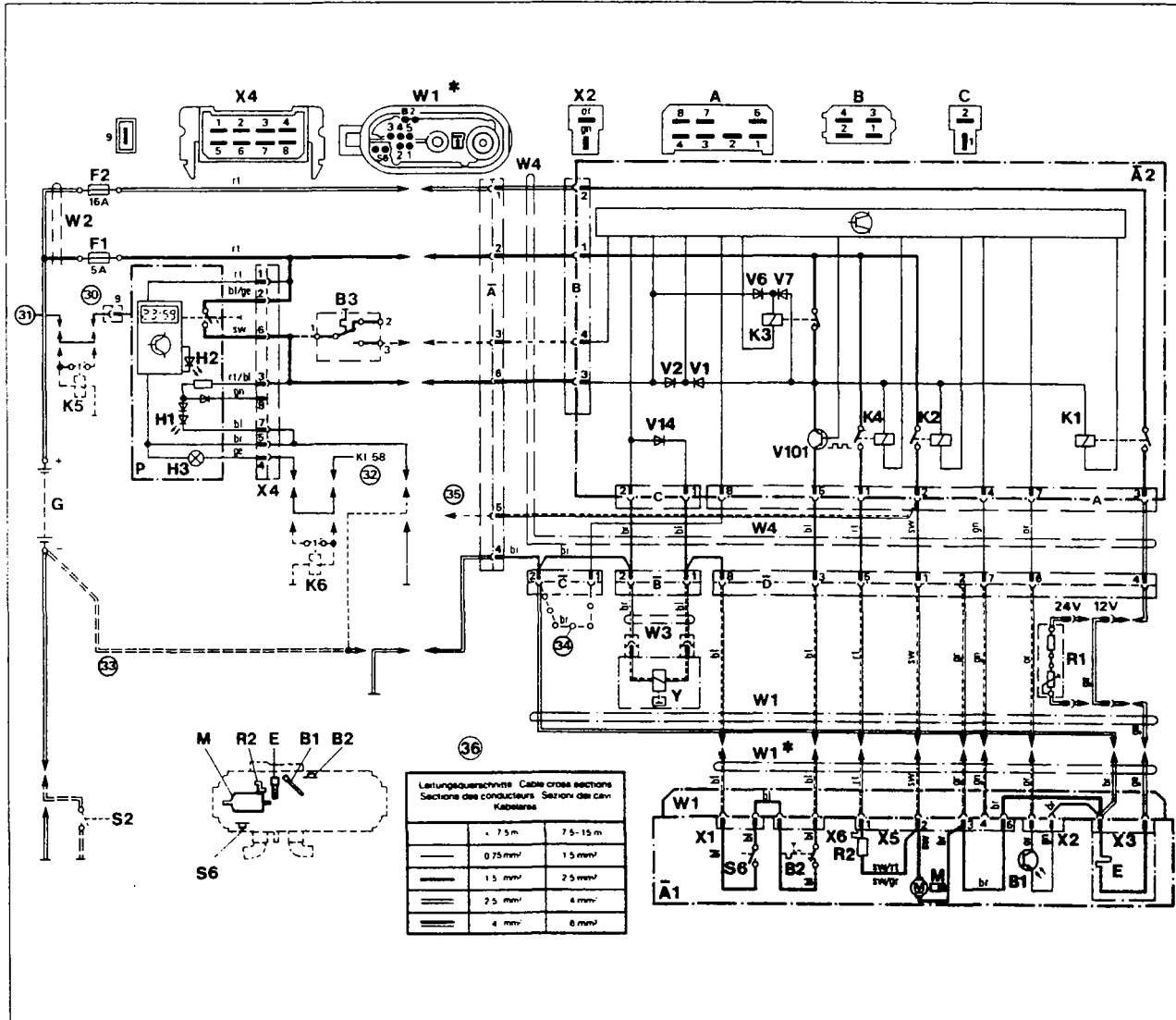

Circuitry of Automatic Control of HL 32 B/D Heaters, 12 and 24 volts, Operation with Timer and Battery Switch (B8014-3000-0003)

Supplied with adapter cable W4 from 08/86 up to approx. 12/86. Only valid in connection with SG1561 part nbr. 462 381 (12V) or SG 1561 part no. 462 403 (24V).

- 30 Timer P:
positive voltage at terminal 9 = continuous operation with instant heat
no positive voltage at terminal 9 = heating period 1 hour
to terminal 75, if present in the vehicle, otherwise terminal 15
- 31 vehicle lighting
- 32 broken lines are alternatives, relays K5 and K6 only when battery switch S2 is used
- 34 remove this connection when using a petrol-fuelled heater
- 35 ventilation
- 36 **NB:** the indicated wire cross sections refer to the supplied (standard) cable. The indicated cross sections must be increased to the next higher value for cable lengths over 7.5 meters.

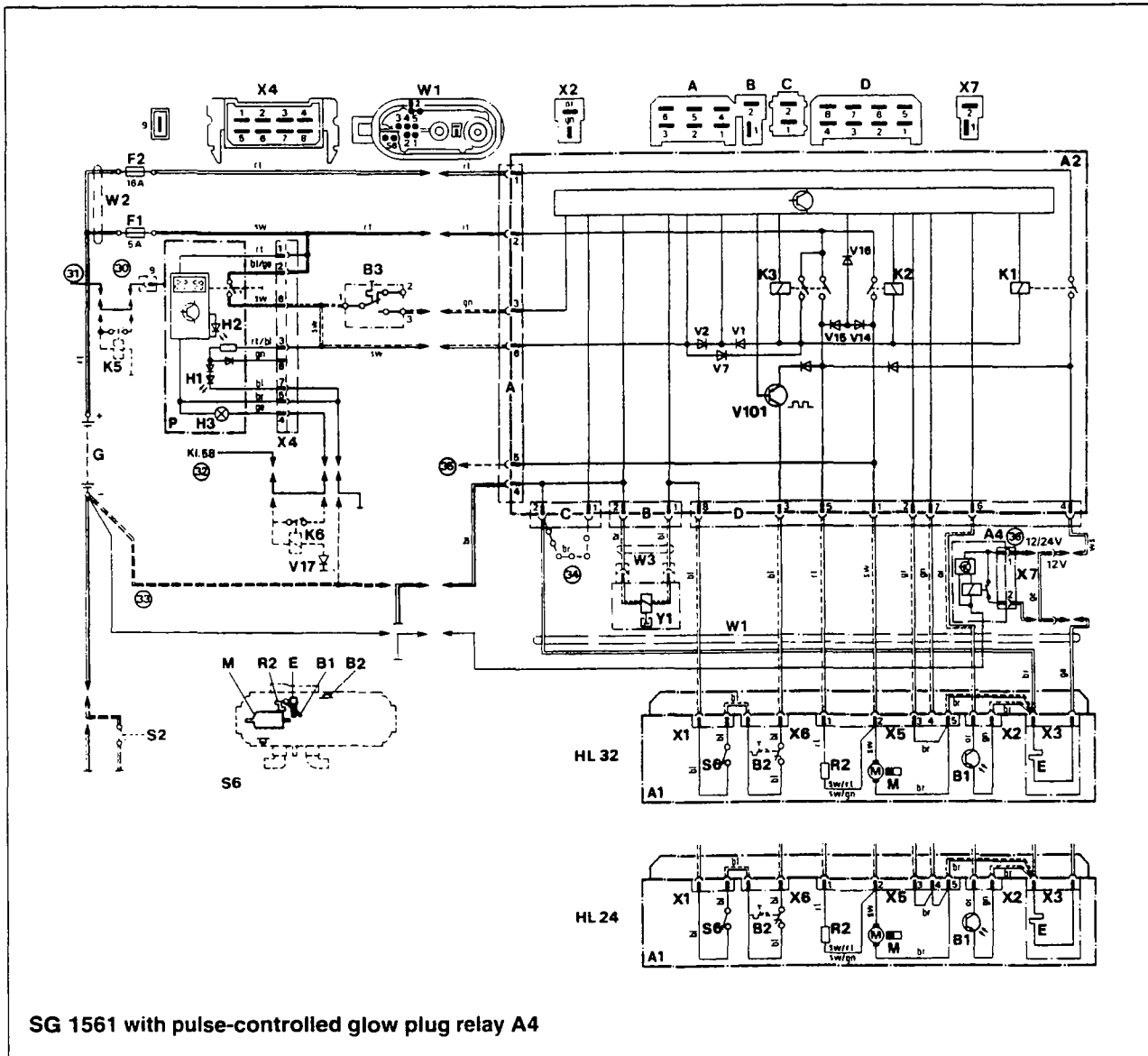

Circuitry of Automatic Control for HL 24/32 B/D Heaters, 12 and 24 volts, Operation with Timer and Battery Switch (B8014-3000-0008/ -0009)

- 30 Timer P:
positive voltage at terminal 9 = continuous operation with instant heat
no positive voltage at terminal 9 = heating period 1 hour
- 31 to terminal 75, if present in the vehicle, otherwise terminal 15
- 32 vehicle lighting
- 33 broken lines are alternatives, relays K5 and K6 only when battery switch S2 is used
- 34 remove this connection when using a petrol-fuelled heater
- 35 ventilation

9 Wiring diagrams

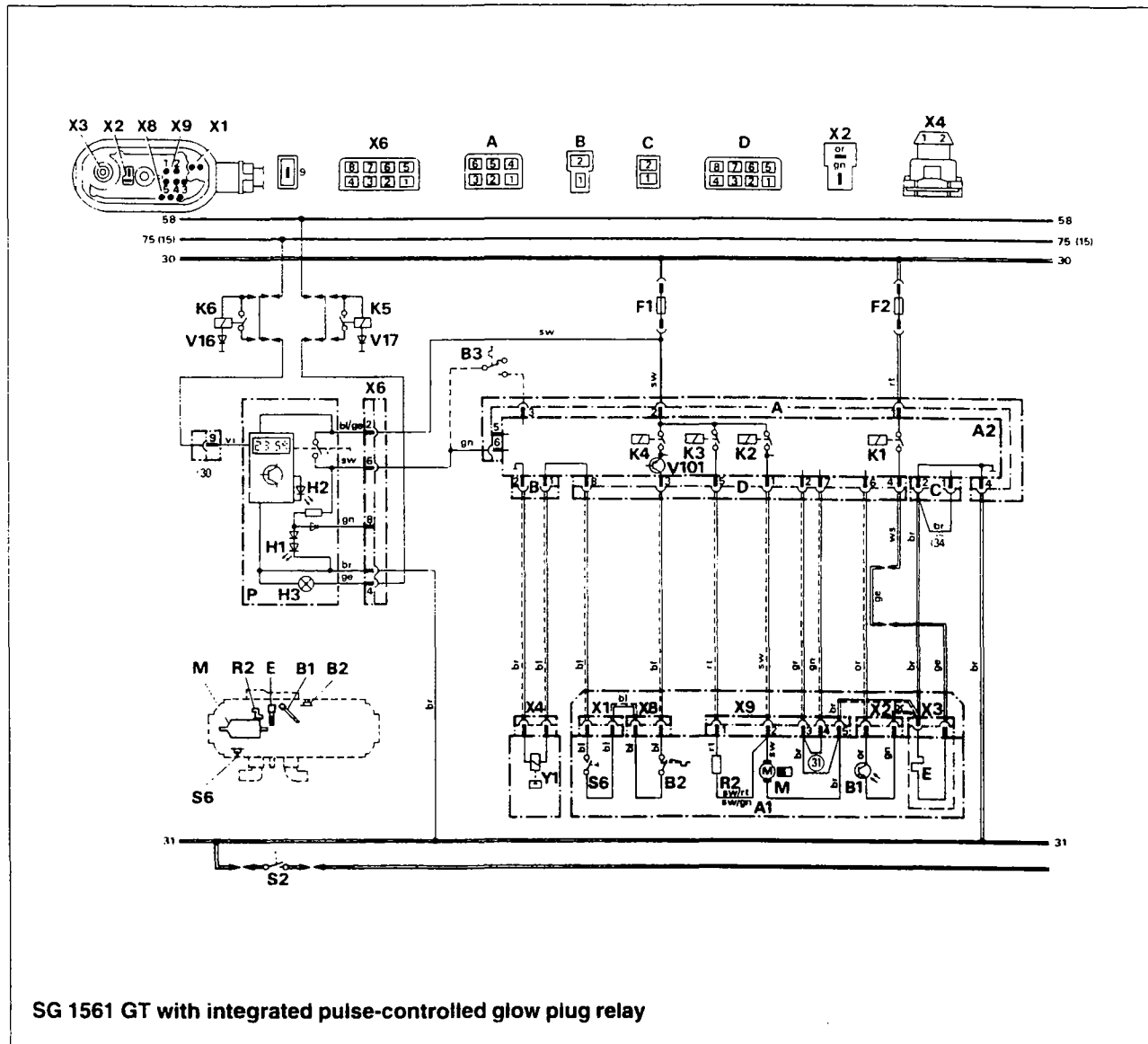

SG 1561 GT with integrated pulse-controlled glow plug relay

Circuitry of Automatic Control for the HL 24/32 B/D Heaters, 12 and 24 volts, Operation with Timer and Battery Switch (B8014-3000-0008/ -0009)

- 30 Timer P:
positive voltage at terminal 9 = continuous operation with instant heat
no positive voltage at terminal 9 = heating period 1 hour
- 31 HL 24 with bridge/ HL 32 without bridge
- 32 vehicle lighting
- 33 relays K5 and K6 only when battery switch S2 is used
- 34 remove this connection when using a petrol-fuelled heater

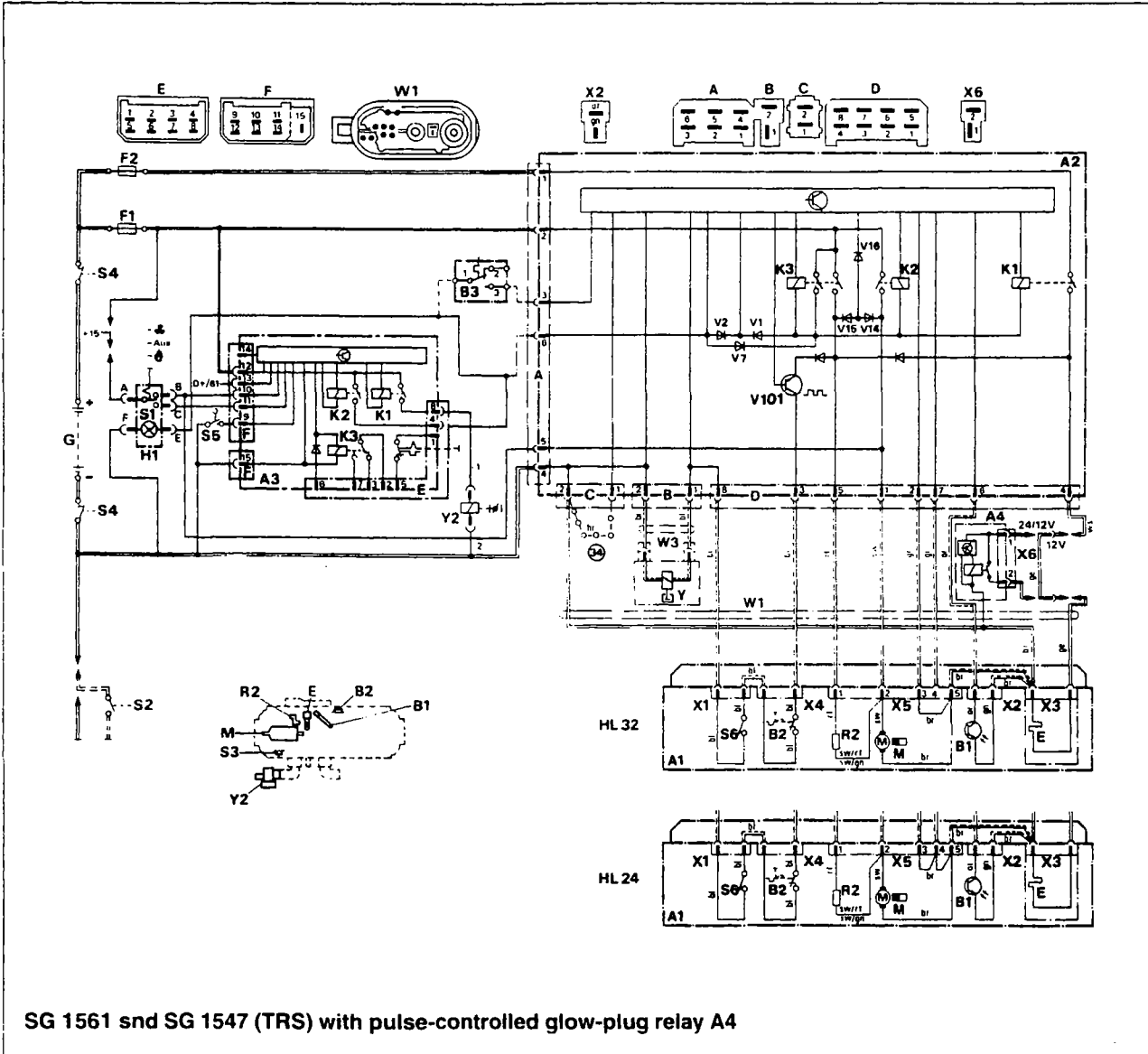

SG 1561 and SG 1547 (TRS) with pulse-controlled glow-plug relay A4

Circuitry of Automatic Control for HL 24 and 32 D (TRS) Heaters, 12 and 24 volts, for Vehicles acc. to TRS 002 and TRS 003 (B 8014-3000-0006/ -0010)

- 1 wire 1
- 2 wire 2
- 34 remove this connection when using a petrol-fuelled heater

When HL24 and 32D (TRS) heaters are to be installed in vehicles designed for the transport of dangerous goods the requirements of TRS 002 and TRS 003 have to be fulfilled in addition to the SIVZO. (TRS = Technical guidelines for dangerous goods - regulation for road transport). For further regulations see Technical Bulletin E3-5.8 (order no. 770 514).
Switch S5 must be so installed that a minus potential is connected when a pumping device is started up.

Legend see page 97

9 Wiring diagrams

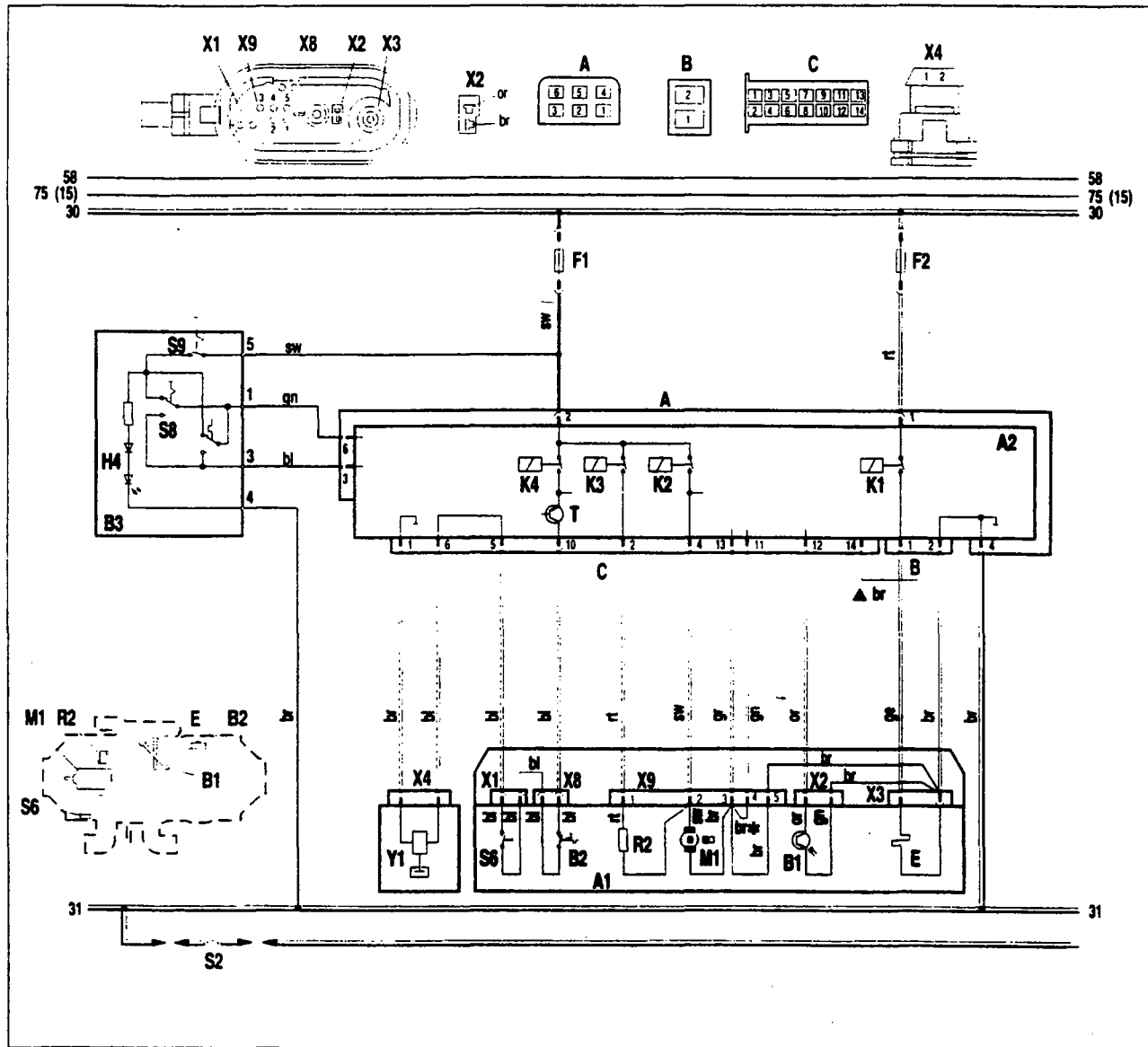

Circuitry of Automatic Control for heaters Air Top 24/32 B/D Heaters, 12 and 24 volts, Operation with Mechanical Interior-Temperature Thermostats

- ∴ HL 24 with bridge/HL 32 without bridge
- ▲ remove this connection when using petrol-fuelled heater

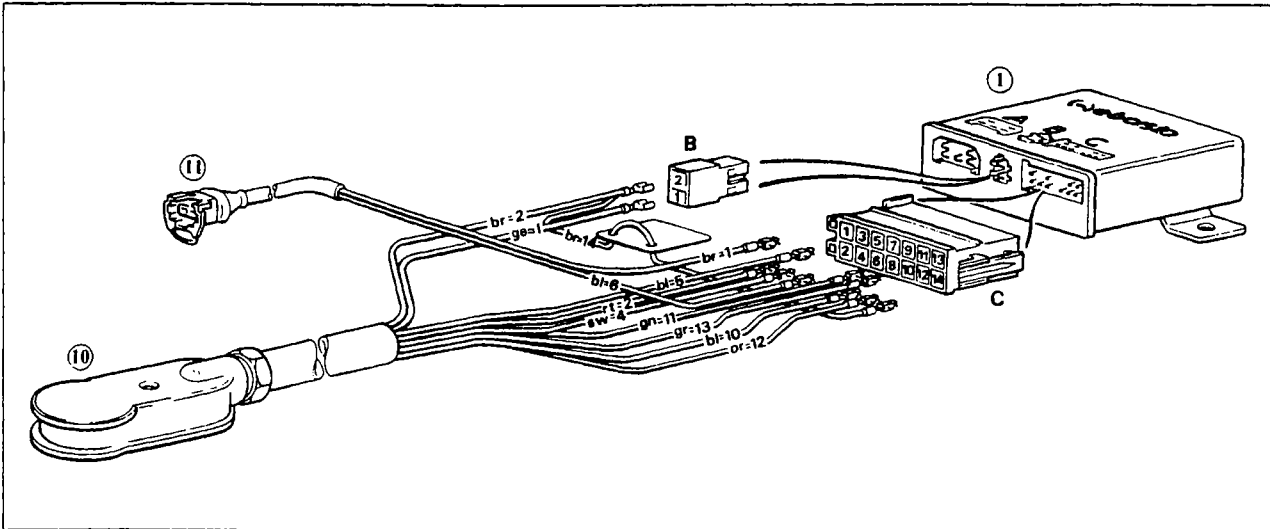

Example of an Application in Connection with Automatic Control Diagram on Page 42, Air Top 24/32

Connection electronic control unit / fuse holder / metering pump

- 1 electronic control unit
- 10 plug to heater
- 11 plug to metering pump

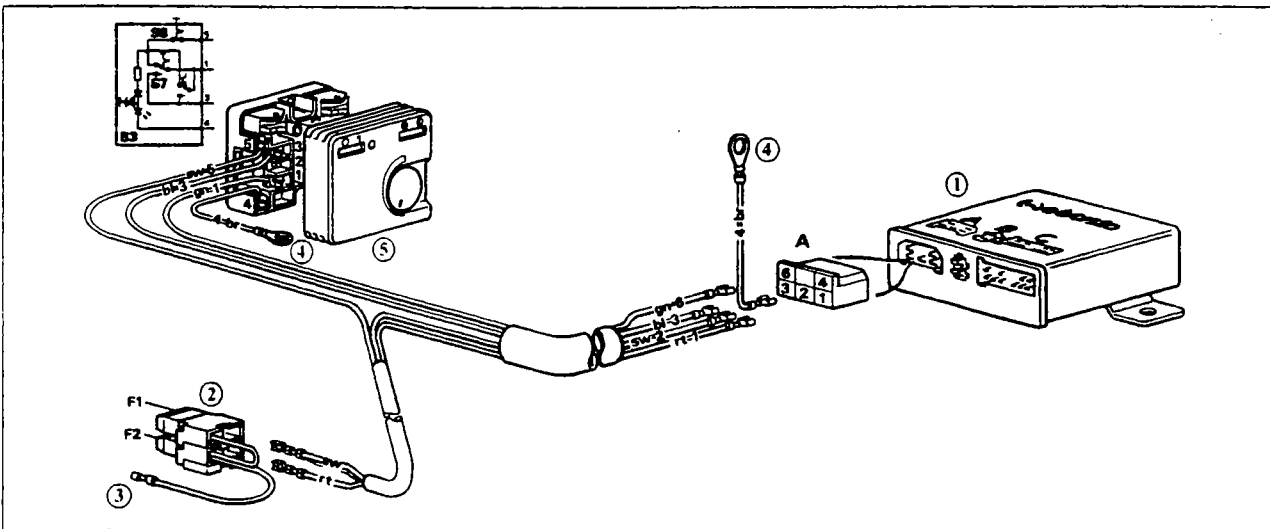

Example of an Application in Connection with Automatic Control Diagram on Page 40, HL 24/32, and Page 42, Air Top 24/32

Connection electronic control unit / fuse holder / interior thermostat (mechanical)

- 1 electronic control unit
- 2 fuse holder
- 3 to battery (+)
- 4 ground (-)
- 5 thermostat (mechanical)

9 Wiring diagrams

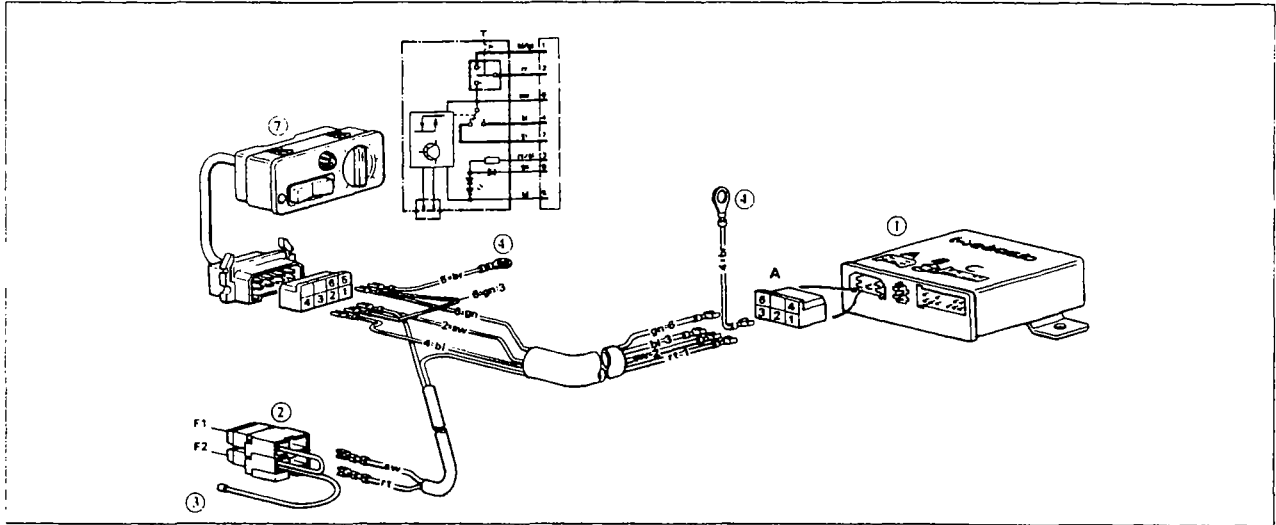

Example of an Application in Connection with Automatic Control Diagram on Page 40, HL 24/32, and on Page 42, Air Top 24/32

Connection electronic control unit / fuse holder / interior thermostat (electronic)

- 1 electronic control unit
- 2 fuse holder
- 3 to battery (+)
- 4 ground (-)
- 7 thermostat (electronic)

For HL 24/32 the additional wire r/bl for ventilation is provided.

NB: In the case of ventilation operation of Air Top 24/32, the application example shown on page 45 must be observed.

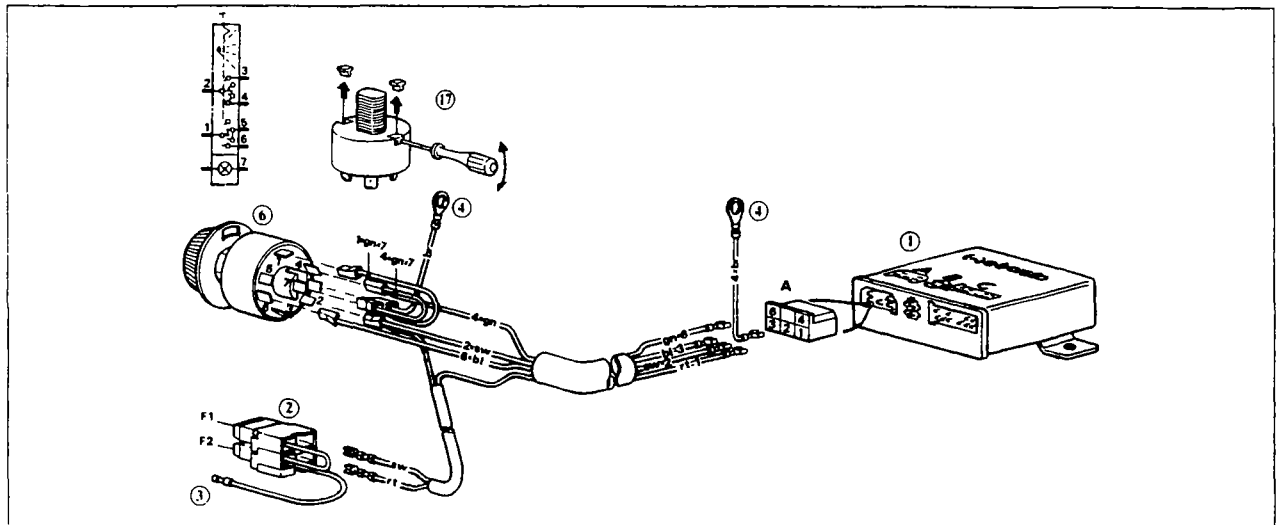

Example of an Application in Connection with Automatic Control Diagram on Page 40, HL 24/32, and on Page 42, Air Top 24/32

Connection electronic control unit / fuse holder / switch

- 1 electronic control unit
- 2 fuse holder
- 3 to battery (+)
- 4 ground (-)
- 6 switch
- 17 remove the two white retaining pins

For HL 24/32 the additional wire r/bl for ventilation is provided.

NB: In the case of ventilation operation of Air Top 24/32, the application example shown on page 45 must be observed.

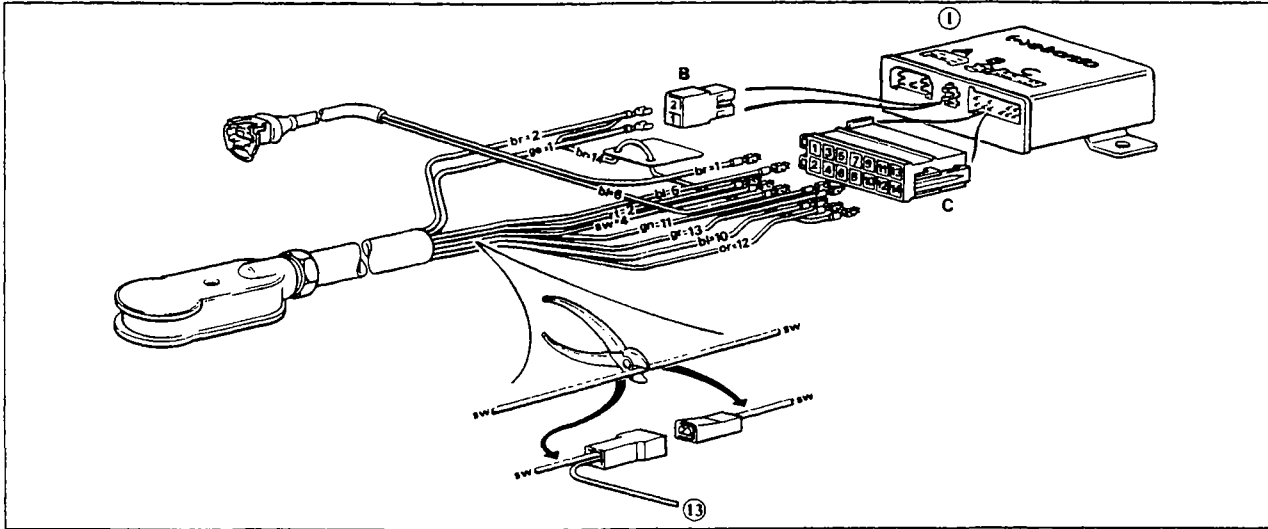

Application Example only for Air Top 24/32

Ventilation operation with switch or interior thermostat (electronic)

- cut wire according to the illustration and establish connection to contact 3 of the switch or contact 1 of the thermostat (electronic).

- 1 electronic control unit
- 13 wiring for switch or thermostat

Owing to the danger of possible interchanging, only r/bl coloured wires to be used.

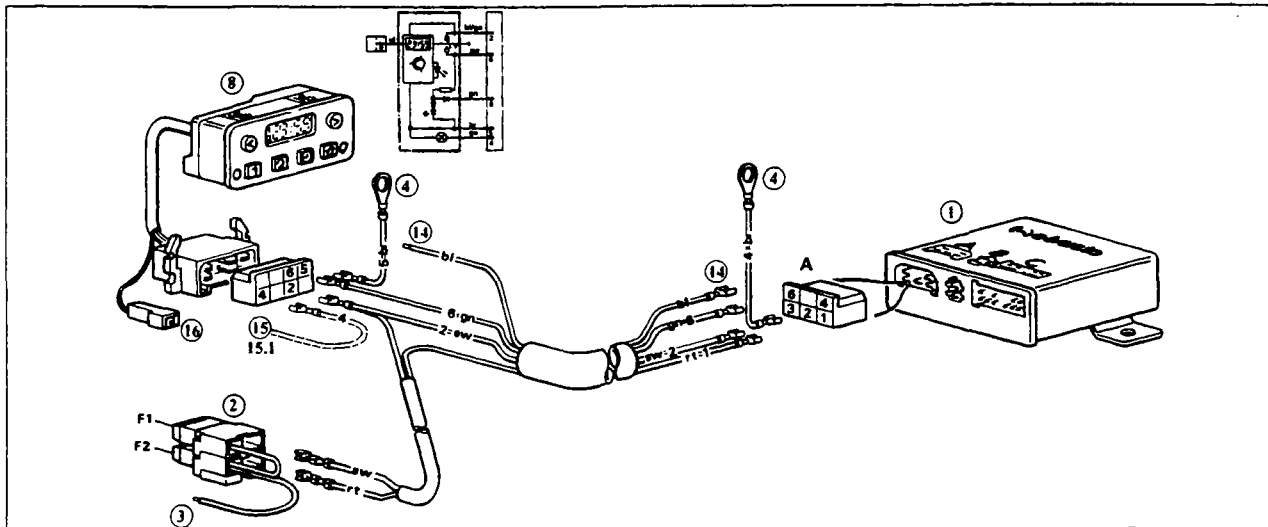

Example of an Application in Connection with Automatic Control Diagram on Page 40, HL 24/32, and on Page 42, Air Top 24/32

Connection electronic control unit/fuse holder/Timer 1522 (24 h)

- 1 electronic control unit
- 2 fuse holder
- 3 to battery (+)
- 4 ground (-)
- 8 Timer 1522 (24 h)
- 14 not used
- 15 illumination (terminal 58)
- 15.1 for battery switch connected to negative voltage, see application example on page 48
- 16 with (+) from terminal (75/15) to terminal 9: continuous operation with instant heat as long as the ignition is turned on
- with (+) from terminal (30) to terminal 9: continuous operation with instant heat
- no positive voltage at terminal 9: heating period 1 hour

9 Wiring diagrams

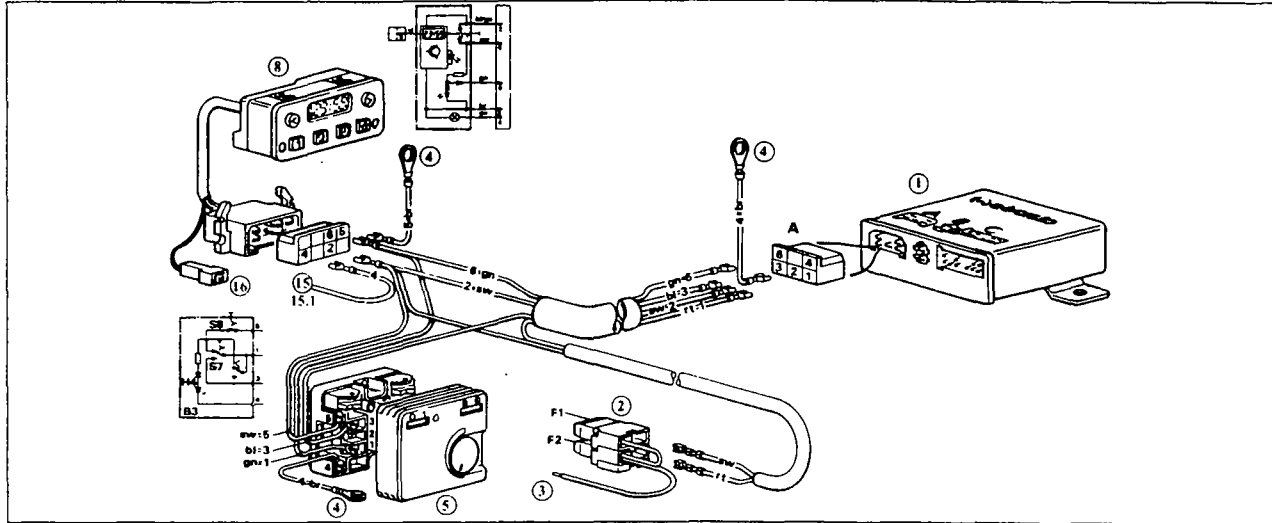

Ex. of an Application in Connection with Aut. Control Diagram on Page 40, HL 24/32, and on Page 42, Air Top 24/32
 Connection electronic control unit/fuse holder/interior thermostat (mechanical)/Timer 1522 (24 h)

- 1 electronic control unit
- 2 fuse holder
- 3 to battery (+)
- 4 ground (-)
- 5 thermostat (mechanical)
- 8 Timer 1522 (24 h)
- 14 not used
- 15 illumination (terminal 58)
- 15.1 for battery switch connected to negative voltage, see application example on page 48
- 16 with (+) from terminal (75/15) to terminal 9: continuous operation with instant heat as long as the ignition is turned on
 with (+) from terminal (30) to terminal 9: continuous operation with instant heat
 no positive voltage at terminal 9: heating period 1 hour

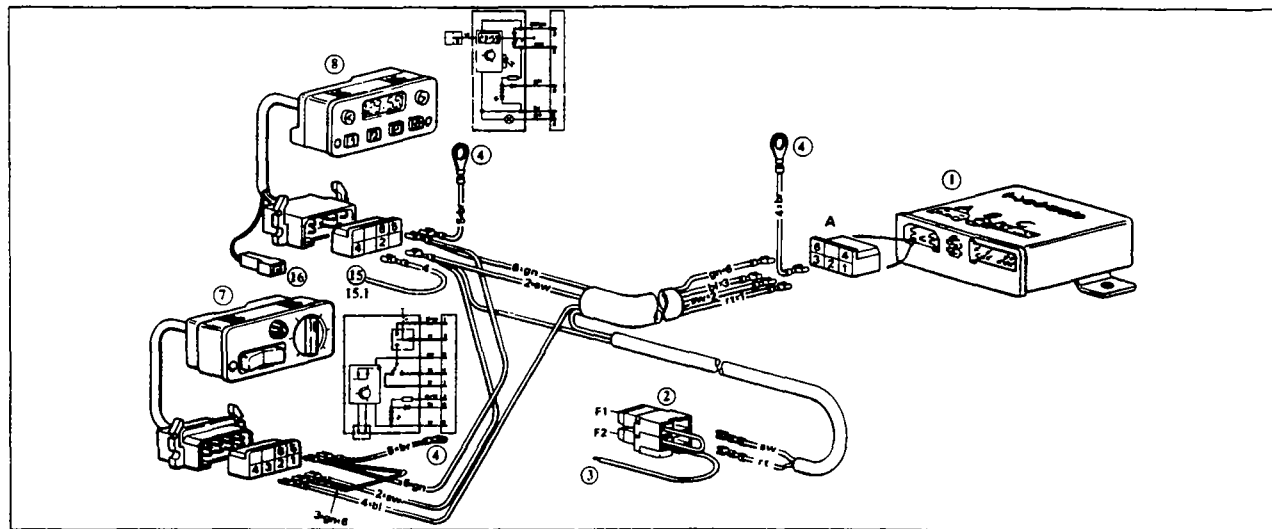

Ex. of an Application in Connection with Aut. Control Diagram on Page 40, HL 24/32, and on Page 42, Air Top 24/32
 Connection electronic control unit/ fuse holder/ interior thermostat (electronic)/Timer 1522 (24 h)

- 1 electronic control unit
- 2 fuse holder
- 3 to battery (+)
- 4 ground (-)
- 7 thermostat (electronic)
- 8 Timer 1522 (24 h)
- 14 not used
- 15 illumination (terminal 58)
- 15.1 for battery switch connected to negative voltage, see application example on page 48
- 16 with (+) from terminal (75/15) to terminal 9: continuous operation with instant heat as long as the ignition is turned on
 with (+) from terminal (30) to terminal 9: continuous operation with instant heat
 no positive voltage at terminal 9: heating period 1 hour

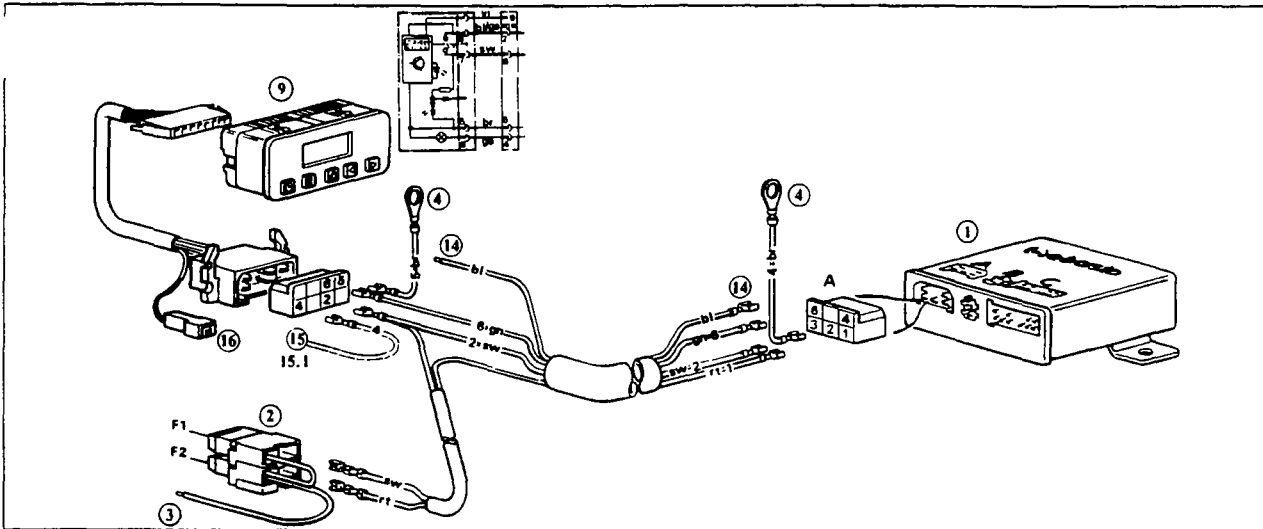

Ex. of an Application in Connection with Aut. Control Diagram on Page 40, HL 24/32, and on Page 42, Air Top 24/32
 Connection electronic control unit/ fuse holder/Timer (7 days)

- 1 electronic control unit
- 2 fuse holder
- 3 to battery (+)
- 4 ground (-)
- 9 Timer (7 days)
- 14 not used
- 15 illumination (terminal 58)
- 15.1 for battery switch connected to negative voltage, see application example on page 48
- 16 with (+) from terminal (75/15) to terminal 9: continuous operation with instant heat as long as the ignition is turned on
 with (+) from terminal (30) to terminal 9: continuous operation with instant heat
 no positive voltage at terminal 9: heating period 1 hour

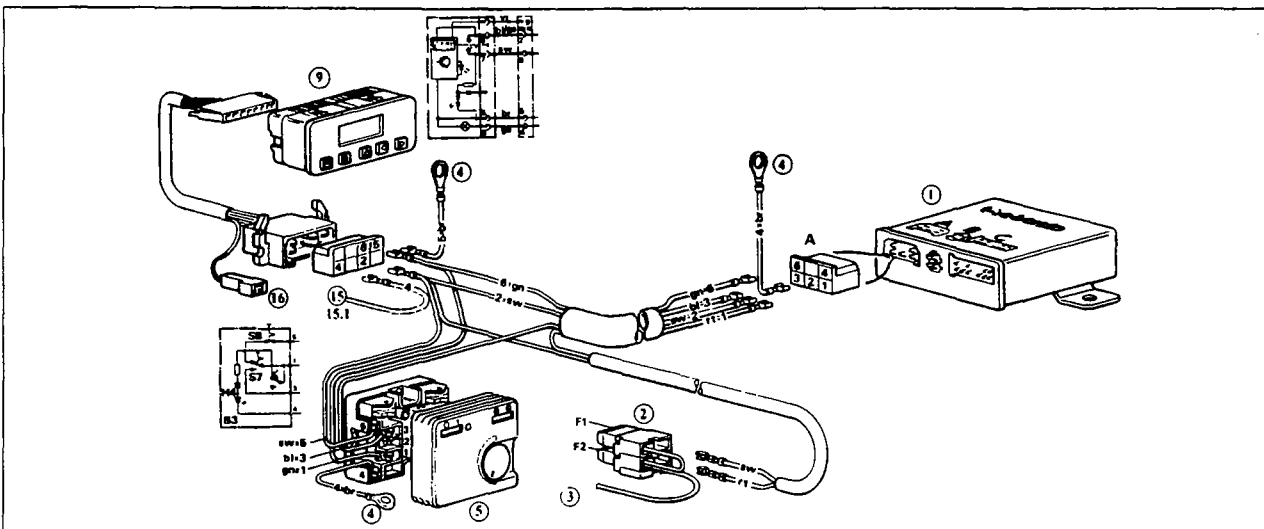

Ex. of an Application in Connection with Aut. Control Diagram on Page 40, HL 24/32, and on Page 42, Air Top 24/32
 Connection electronic control unit/ fuse holder/ interior thermostat (mechanical)/ Timer (7 days)

- 1 electronic control unit
- 2 fuse holder
- 3 to battery (+)
- 4 ground (-)
- 5 thermostat (mechanical)
- 9 Timer (7 days)
- 14 not used
- 15 illumination (terminal 58)
- 15.1 for battery switch connected to negative voltage, see application example on page 48
- 16 with (+) from terminal (75/15) to terminal 9: continuous operation with instant heat as long as the ignition is turned on
 with (+) from terminal (30) to terminal 9: continuous operation with instant heat
 no positive voltage at terminal 9: heating period 1 hour

9 Wiring diagrams

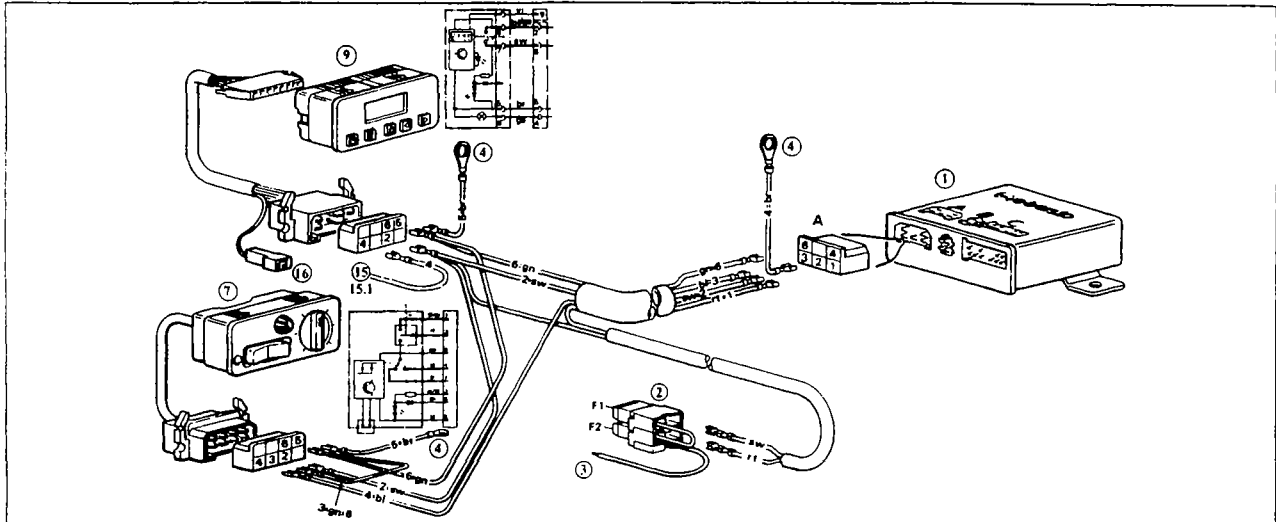

Ex. of an Application in Connection with Aut. Control Diagram on Page 40, HL 24/32, and on Page 42, Air Top 24/32
 Connection electronic control unit/ fuse holder/ interior thermostat (electronic)/ Timer (7 days)

- 1 elektronik control unit
- 2 fuse holder
- 3 to battery (+)
- 4 ground (-)
- 7 thermostat (electronic)
- 9 Timer (7 days)
- 14 not used
- 15 illumination (terminal 58)
- 15.1 for battery switch connected to negative voltage, see application example on page 48
- 16 with (+) from terminal (75/15) to terminal 9: continuous operation with instant heat as long as the ignition is turned on
 with (+) from terminal (30) to terminal 9: continuous operation with instant heat
 no positive voltage at terminal 9: heating period 1 hour

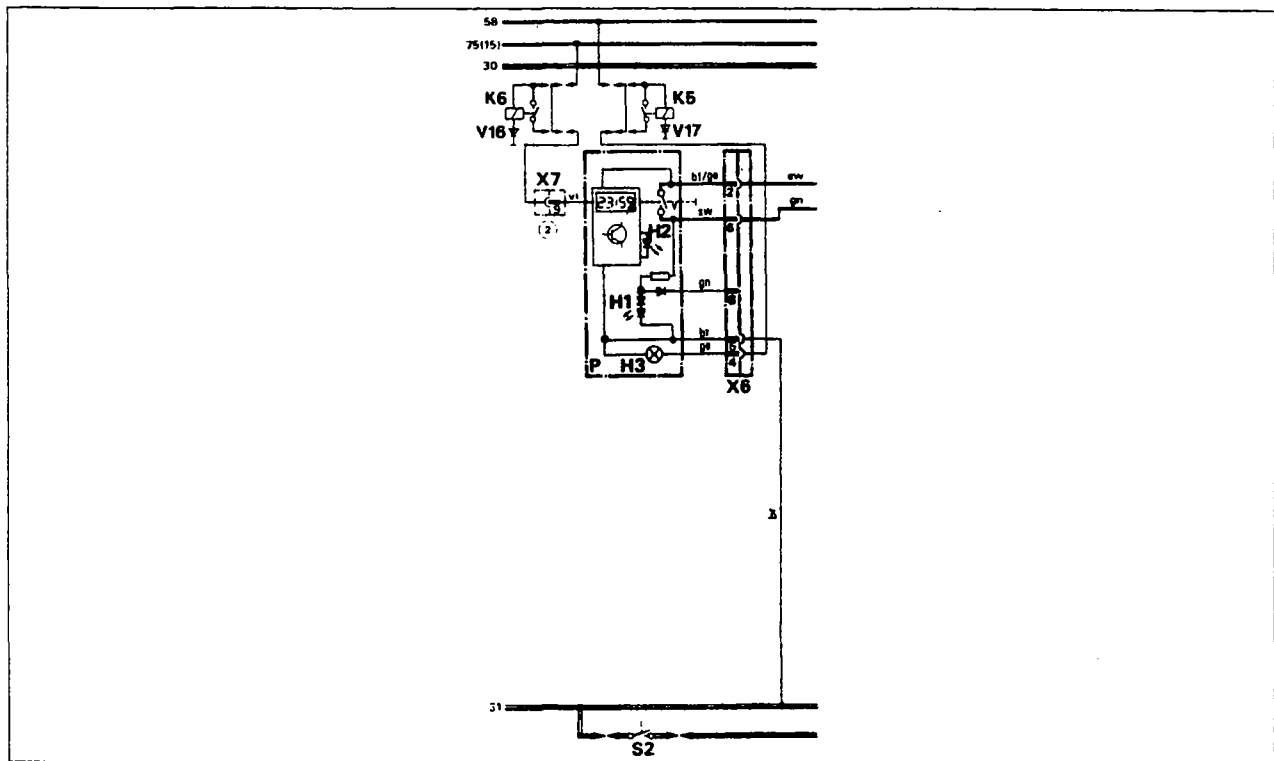

Application example: only applicable if battery switch is connected to negative voltage



Org. 01/1994 P/N 907402

Webasto
Feel the drive

Webasto Product N.A., Inc.
Technical Assistance Hotline
USA: (800) 555-4518
Canada: (800) 667-8900

www.webasto.us